



CML Tape & Reel Specification

MQSE6

Issue 11

Apr 2025

This document defines the Tape & Reel specifications available from CML.

Copyright Statement

The copyright of this document is the property of CML Microcircuits (UK) Limited. Without the written consent of CML Microcircuits (UK) Limited, given by contract or otherwise, this document must not be copied, reprinted, or reproduced in any material form, either wholly or in part, and the contents of this document, or any methods or techniques available there from, must not be disclosed to any person whatsoever.

Contents

	<u>Page</u>
1 Scope.....	3
2 Dimensions.....	3
2.1 Tape Width (W)	3
2.2 Carrier Tape Thickness (t).....	3
2.3 Pitch of Sprocket Holes (P0)	3
2.4 Diameter of Sprocket Holes (D)	3
2.5 Distance Sprocket Hole Centre to Tape Edge (E)	3
2.6 Distance Sprocket Hole Centre to Centre Hole (F)	4
2.7 Dimension (P2).....	4
2.8 Embossed Pocket Dimensions (A0 & B0).....	5
2.9 Embossed Tape Dimension (K0)	6
2.10 Pitch of Component Pockets (P1)	6
2.11 Outside Dimension of Pocket (B1)	7
2.12 Pocket Centre Hole Diameter (D1).....	7
3 Materials	7
4 Polarity & Orientation of Components in Tape	7
5 Fixing of Components in Tape.....	7
6 Packaging	8
6.1 13" Reel Dimensions (in millimetres).....	8
6.2 7" Reel Dimensions (in millimetres).....	8
7 Drawings.....	10
8 Related Documents	14
9 Machine and File ID.....	14
10 History.....	14

1 Scope

The specification relates to the tape packaging of integrated circuits suitable for surface mount assembly. It includes only those dimensions that are essential for the purchaser to use this product..

2 Dimensions

(Refer to figure 1a & 1b)

2.1 Tape Width (W)

Package style A6, Q5, Q8, QT8, A4	W =	12.0 +0.3/-0.1	mm
A7, Q6, Q7, QF, QH, QK	W =	12.0 ± 0.3	mm
D4, D5, D6 E1, E2, E3, E4 L4, Q2, Q3, Q4	W =	16.0 ± 0.3	mm
Q1, QT1, T1	W =	16.0 +0.3/-0.1	mm
D1, D2, D3 L8, L9, B1	W =	24.0 ± 0.3	mm

2.2 Carrier Tape Thickness (t)

All D's, E's, L's, Q's, A7 A6, B1	t =	0.30 ± 0.5	mm	max
A4	t =	0.25 ± 0.5	mm	max

2.3 Pitch of Sprocket Holes (P₀)

All package styles	P ₀ =	4.0 ± 0.2	mm
--------------------	------------------	-----------	----

2.4 Diameter of Sprocket Holes (D)

All package styles	D =	1.5 + 0.1/- 0.0	mm
--------------------	-----	-----------------	----

2.5 Distance Sprocket Hole Centre to Tape Edge (E)

All package styles	E =	1.75 ± 0.1	mm
--------------------	-----	------------	----

2.6 Distance Sprocket Hole Centre to Centre Hole (F)

Package style Q5, Q6, Q7 Q8, QT8, QF, QH, QK, A4, A6, A7	F = 5.5 ± .05	mm
D4, D5, D6 E1, E2, E3, E4 L4 Q1, QT1, Q2, Q3, Q4 T1	F = 7.5 ± 0.1	mm
D1, D2, D3 L8, L9, B1	F = 11.5 ± 0.1	mm

2.7 Dimension (P2)

B1 D1, D2, D3, D4, D5, D6 E1, E2, E3, E4 L4, L8, L9 Q1, Q2, Q3, Q4, QT1 T1	P2 = 2.0 ± 0.1	mm
A4, A6, A7 Q5, Q6, Q7, Q8, QT8, QF, QH, QK	P2 = 2.0 ± 0.05	mm

2.8 Embossed Pocket Dimensions (A₀ & B₀)

Package style			
D1	A ₀	= 10.9 ± 0.1	mm
	B ₀	= 18.3 ± 0.1	mm
D2	A ₀	= 10.9 ± 0.1	mm
	B ₀	= 15.8 ± 0.1	mm
D3	A ₀	= 10.9 ± 0.1	mm
	B ₀	= 13.2 ± 0.1	mm
D4	A ₀	= 10.9 ± 0.1	mm
	B ₀	= 10.7 ± 0.1	mm
D5	A ₀	= 8.2 ± 0.1	mm
	B ₀	= 8.8 ± 0.1	mm
D6	A ₀	= 8.4 ± 0.1	mm
	B ₀	= 10.7 ± 0.1	mm
E1	A ₀	= 6.8 ± 0.1	mm
	B ₀	= 10.2 ± 0.1	mm
E2	A ₀	= 6.95 ± 0.1	mm
	B ₀	= 8.3 ± 0.1	mm
E3	A ₀	= 6.8 ± 0.1	mm
	B ₀	= 6.9 ± 0.1	mm
E4	A ₀	= 6.8 ± 0.1	mm
	B ₀	= 5.4 ± 0.1	mm
L4	A ₀	= 9.3 ± 0.1	mm
	B ₀	= 9.3 ± 0.1	mm
L8	A ₀	= 16.5 ± 0.1	mm
	B ₀	= 16.5 ± 0.1	mm
L9	A ₀	= 12.5 ± 0.1	mm
	B ₀	= 12.5 ± 0.1	mm
Q1, QT1	A ₀	= 9.3 ± 0.1	mm
	B ₀	= 9.3 ± 0.1	mm
Q2	A ₀	= 8.3 ± 0.1	mm
	B ₀	= 8.3 ± 0.1	mm
Q3, T1	A ₀	= 7.25 ± 0.1	mm
	B ₀	= 7.25 ± 0.1	mm
Q4	A ₀	= 6.3 ± 0.1	mm
	B ₀	= 6.3 ± 0.1	mm
Q5, Q8, QT8	A ₀	= 5.25 ± 0.1	mm
	B ₀	= 5.25 ± 0.1	mm
Q6, Q7, QH	A ₀	= 4.35 ± 0.1	mm
	B ₀	= 4.35 ± 0.1	mm
QF	A ₀	= 3.30 ± 0.1	mm
	B ₀	= 3.30 ± 0.1	mm
QK	A ₀	= 4.3 ± 0.1	mm
	B ₀	= 5.3 ± 0.1	mm
B1	A ₀	= 10.3 ± 0.1	mm
	B ₀	= 10.3 ± 0.1	mm
A4	A ₀	= 3.42 ± 0.05	mm
	B ₀	= 3.50 ± 0.05	mm
A6	A ₀	= 4.35 ± 0.1	mm
	B ₀	= 4.35 ± 0.1	mm
A7	A ₀	= 4.30 ± 0.1	mm
	B ₀	= 4.30 ± 0.1	mm

2.9 Embossed Tape Dimension (K₀)

Package style			
D1, D2, D3, D4	K ₀	= 3.0 ± 0.1	mm
D5	K ₀	= 2.5 ± 0.1	mm
D6	K ₀	= 2.4 ± 0.1	mm
E1, E2, E3, E4	K ₀	= 1.6 ± 0.1	mm
L4, L9	K ₀	= 2.2 ± 0.1	mm
L8	K ₀	= 1.9 ± 0.1	mm
Q1	K ₀	= 1.1 ± 0.1	mm
QT1	K ₀	= 1.1 ± 0.1	mm
Q2	K ₀	= 1.1 ± 0.1	mm
Q3	K ₀	= 1.1 ± 0.1	mm
Q4	K ₀	= 1.1 ± 0.1	mm
Q5, Q8, QT8	K ₀	= 1.1 ± 0.1	mm
Q6, Q7, QH	K ₀	= 1.1 ± 0.1	mm
QF	K ₀	= 1.1 ± 0.1	mm
QK	K ₀	= 1.1 ± 0.1	mm
A4	K ₀	= 0.82 ± 0.05	mm
A6	K ₀	= 1.6 ± 0.1	mm
A7	K ₀	= 1.40 ± 0.1	mm
B1	K ₀	= 2.1 ± 0.1	mm
T1	K ₀	= 1.3 ± 0.1	mm

2.10 Pitch of Component Pockets (P₁)

Package style			
E1, E2, E3, E4 Q5, Q6, Q7, Q8, QT8 QF, QH, QK A4, A6, A7	P ₁	= 8.0 ± 0.1	mm
D1, D2, D3, D4 D5, D6 L4, T1 Q1, QT1, Q2, Q3, Q4	P ₁	= 12 ± 0.1	mm
L9, B1	P ₁	= 16 ± 0.1	mm
L8	P ₁	= 20 ± 0.1	mm

2.11 Outside Dimension of Pocket (B1)

Package style				
D1	B1	=	18.9 ± 0.2	mm
D2	B1	=	16.5 ± 0.2	mm
D3	B1	=	13.9 ± 0.2	mm
D4	B1	=	11.4 ± 0.2	mm
D5	B1	=	9.3 ± 0.2	mm
D6	B1	=	11.4 ± 0.2	mm
E1	B1	=	10.9 ± 0.2	mm
E2	B1	=	9.0 ± 0.2	mm
E3	B1	=	7.6 ± 0.2	mm
E4	B1	=	6.3 ± 0.2	mm
L4	B1	=	9.9 ± 0.2	mm
L8	B1	=	17.1 ± 0.2	mm
L9	B1	=	13.0 ± 0.2	mm
Q1, QT1	B1	=	10.4 ± 0.2	mm
Q2	B1	=	9.4 ± 0.2	mm
Q3, T1	B1	=	8.4 ± 0.2	mm
Q4	B1	=	7.4 ± 0.2	mm
Q5, Q8, QT8, QK	B1	=	6.4 ± 0.2	mm
A6, Q6, Q7, QH	B1	=	5.4 ± 0.2	mm
QF	B1	=	4.4 ± 0.2	mm
B1	B1	=	11.4 ± 0.2	mm
A4	B1	=	4.6 ± 0.2	mm
A7	B1	=	5.4 ± 0.2	mm

2.12 Pocket Centre Hole Diameter (D1)

Package style	
D1, D2, D3, D4, D5, D6	
E1, E2, E3, E4	
L4, L8, L9	
Q1, QT1, Q2, Q3, Q4, Q5, Q6 Q7, Q8, QT8, QF, QH, QK, T1, B1 A4, A6, A7	D1 = 1.5mm Minimum

3 Materials

1. Carrier tape to be made of a conductive grade of polystyrene.
2. Conductive grade polycarbonate is also an approved carrier tape material and may be used under certain circumstances.
3. Temperature sealed cover tape is an anti static grade of PET/PE film.

4 Polarity & Orientation of Components in Tape

1. All components are placed such that pin 1 is adjacent to the sprocket holes (See figures 6a, 6b, 6c, 6d, 6e & 6f)
2. The mounting side of the component is oriented to the bottom side of the tape (See Figure 2).

5 Fixing of Components in Tape

1. The cover tape shall not cover the sprocket holes in the carrier tape
2. Tapes in adjacent layers shall not stick together in the packing.
3. The adhesive of the cover tape shall not adversely affect the mechanical and electrical characteristics and the marking of the component.

4. Components will not stick to the carrier tape or the cover tape.
5. The tapes shall be suitable to withstand storage of the taped components without danger of migration of the terminations or the giving off of vapours, which would impair soldering or deteriorate the component properties or termination by chemical action.
6. When the tape is bent with a minimum radius (See Figure 5), the tape shall not be damaged and the components shall remain in their position and orientation in the tape.
7. The peel strength of the cover tape shall be 60 + 40/-30 grams measured at 175° –180° with respect to the carrier tape along its longitudinal axis. The peel speed shall be 300mm/min.
8. After baking at 50°C for 60 hours or storage in ideal conditions for three months the peel strength shall remain within the specified limits.

6 Packaging

1. The tape will be wound on anti-static high impact polystyrene reels (See Figure 4).

6.1 13" Reel Dimensions (in millimetres)

W Tape Width	A Reel Dia.	C Centre Hole Dia.	N Hub Outer Dia.	W1 Inside Cheek Width	W2 Outside Cheek Width	Product types
12	330	13	101	12.8	17.3	All
16	330	13	101	16.8	21.3	All
24	330	13	101	24.8	29.3	All except L8
24	330	13	175	24.8	29.3	L8 only
32	330	13	101	32.8	37.3	All

6.2 7" Reel Dimensions (in millimetres)

W Tape Width	A Reel Dia.	C Centre Hole Dia.	N Hub Outer Dia.	W1 Inside Cheek Width	W2 Outside Cheek Width	Product types
12	180	13	60	13	15.4	Q5, Q6, Q7, Q8, QT8, QF, QH, QK, A4, A6, A7
16	180	13	60	17	19.4	E1, E2, E3, E4 Q1,QT1, Q2,Q3,Q4

2. There will be a leader of a minimum of 400 mm of covered empty compartments.
3. In no case shall there be two or more consecutive components missing. The maximum number of missing components per reel shall be one or 0.1% whichever is greater.
4. At the end of the tape, there will be a trailer of a minimum of 160 mm of sealed empty pockets.
5. The tape shall release from the reel hub as the last portion of the carrier tape unwinds from the reel.
6. Standard numbers of components on reels:

7" Reel

13" Reel

Package style	=	Minimum Quantity	Maximum Quantity	Package style	=	Minimum Quantity	Maximum Quantity
D1	=	-	-	D1	=	1,000	1,500
D2	=	-	-	D2	=	1,000	1,500
D3	=	-	-	D3	=	1,000	1,500
D4	=	-	-	D4	=	1,000	1,500
D5	=	-	-	D5	=	1,000	-

D6	=	-	-	D6	=	1,000	-
E1	=	-	1,000	E1	=	-	3,000
E2	=	-	1,000	E2	=	-	3,000
E3	=	-	1,000	E3	=	-	3,000
E4	=	-	1,000	E4	=	-	3,000
L4	=	-	-	L4	=	1,000	-
L8	=	-	-	L8	=	1,000	-
L9	=	-	-	L9	=	1,000	-
Q1	=	-	1,000	Q1	=	-	3,500
QT1	=	-	1,000	QT1	=	-	3,500
Q2	=	-	1,000	Q2	=	-	3,500
Q3	=	-	1,000	Q3	=	-	3,500
Q4	=	-	1,000	Q4	=	-	3,500
Q5	=	-	1,000	Q5	=	-	5,000
Q6	=	-	1,000	Q6	=	-	5,000
Q7	=	-	1,000	Q7	=	-	5,000
Q8	=	-	1,000	Q8	=	-	5,000
QT8	=	-	1,000	QT8	=	-	5,000
QF	=	-	1,000	QF	=	-	5,000
QH	=	-	1,000	QH	=	-	5,000
QK	=	-	1,000	QK	=	-	5,000
A4	=	-	1,000	A4	=	-	5,000
A6	=	-	1,000	A6	=	-	5,000
A7	=	-	1,000	A7	=	-	4,500
B1	=	-	-	B1	=	1,000	1,500
T1	=	-	-	T1	=	1,000	3,500

7. The tape will be prevented from unreeling by winding a tape around the reel and fixing with adhesive tape.
8. All reels will display:
 1. Device Type
 2. Quantity on reel
 3. A CML serial number or bar code or QR code, or both bar code & QR code.
 4. The date reel sealed.
 5. A static hazard warning label
9. Reels are packed in an anti-static bubble bag or a moisture barrier bag inside a cardboard box with appropriate labelling (Ref Pi-34).
10. Ideal storage conditions for sealed tape are 15°C to 20°C with a relative humidity less than 60%.
11. Shelf life of sealed tape when stored in ideal conditions will be in excess of six months.

7 Drawings

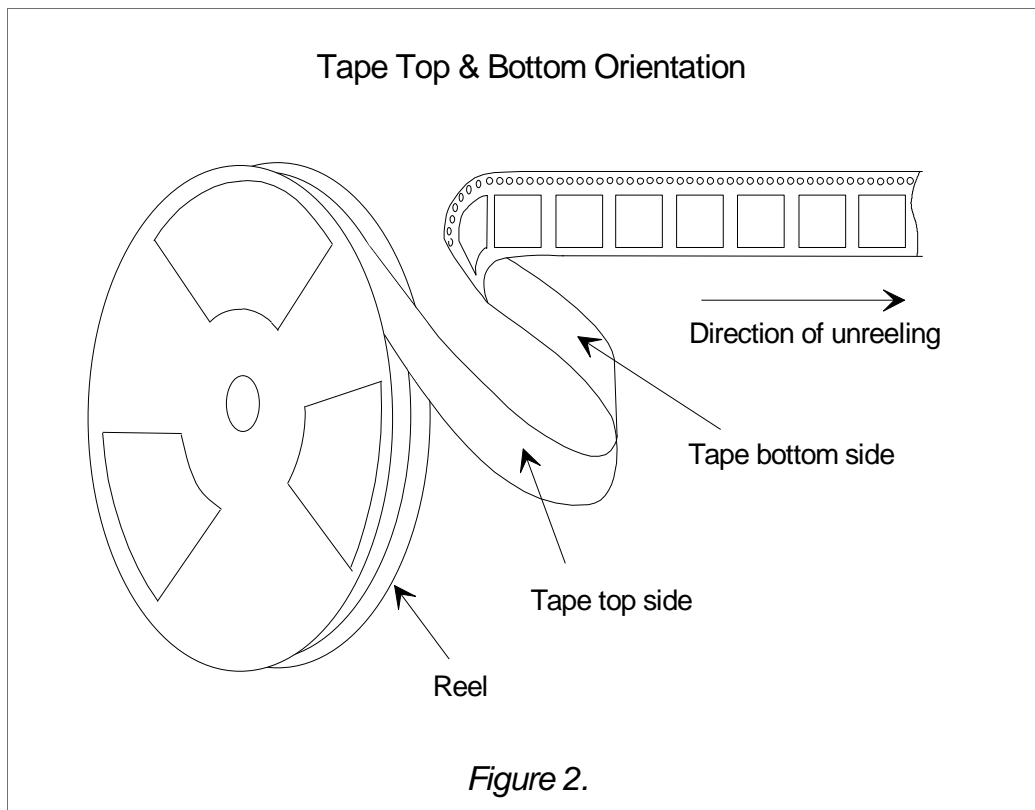
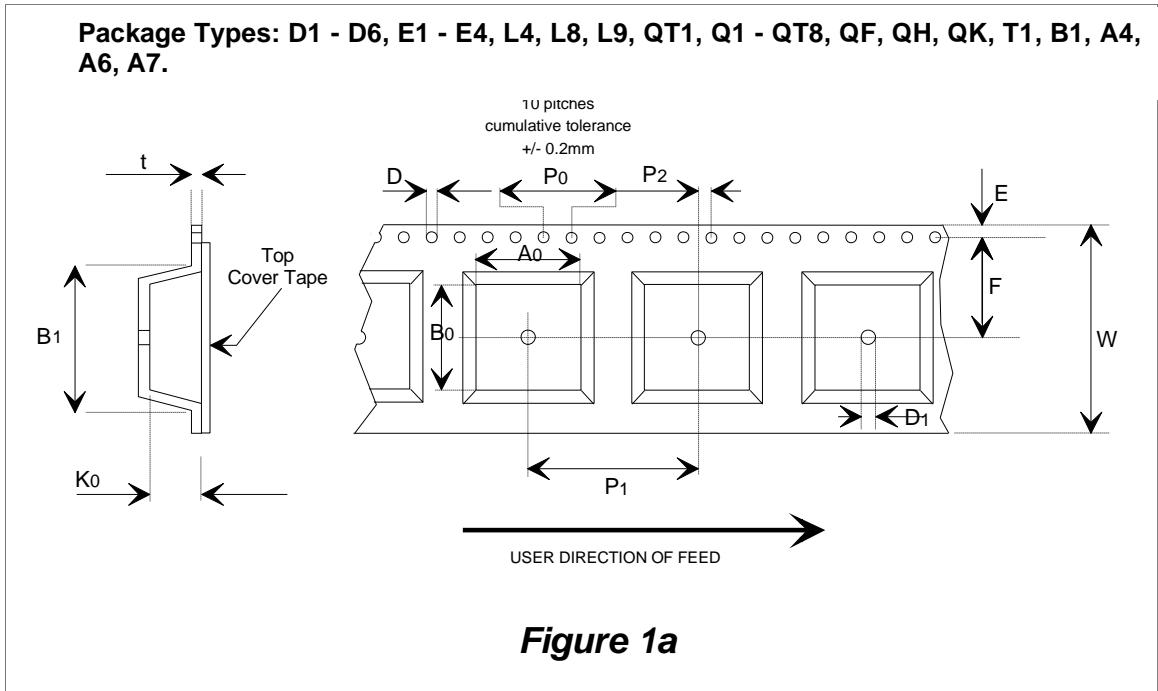

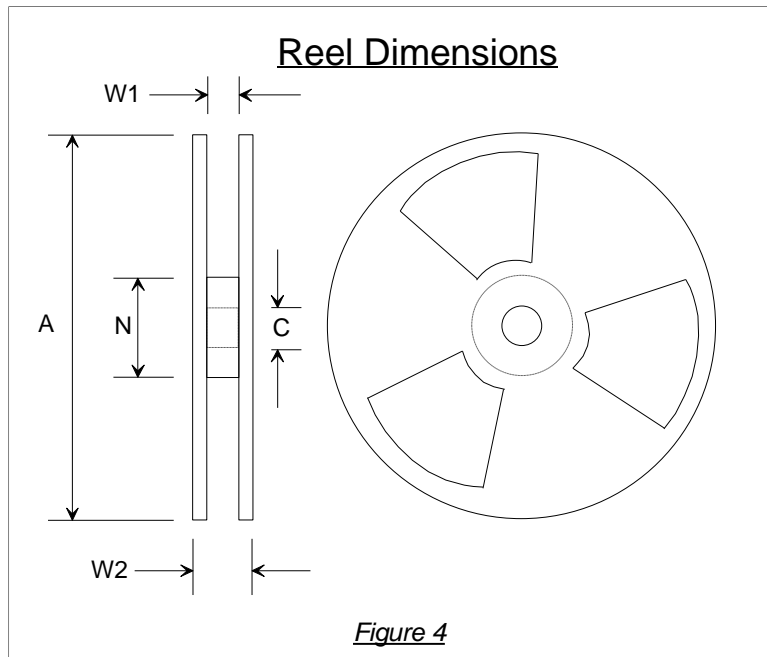
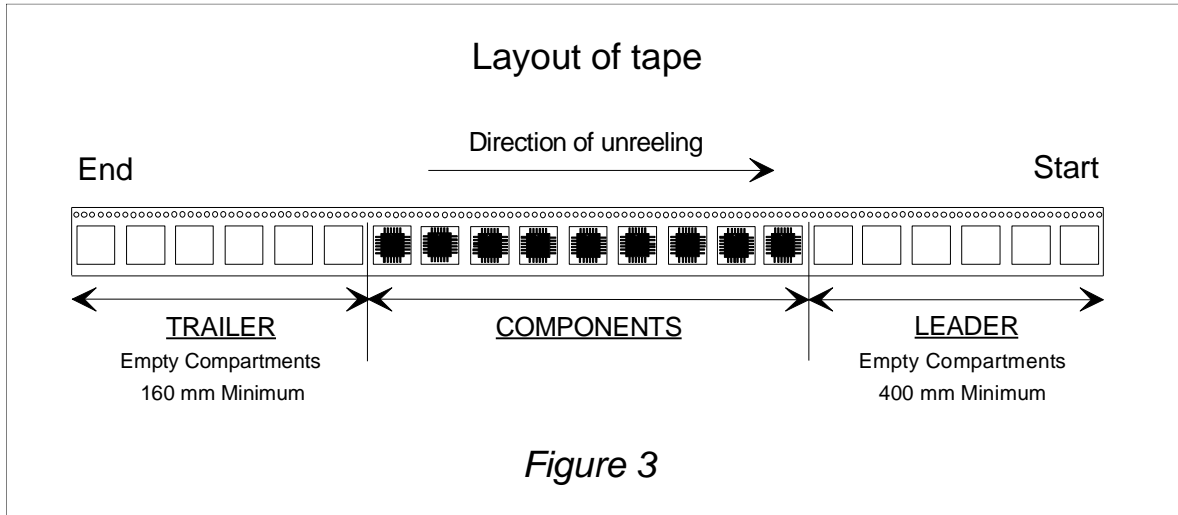

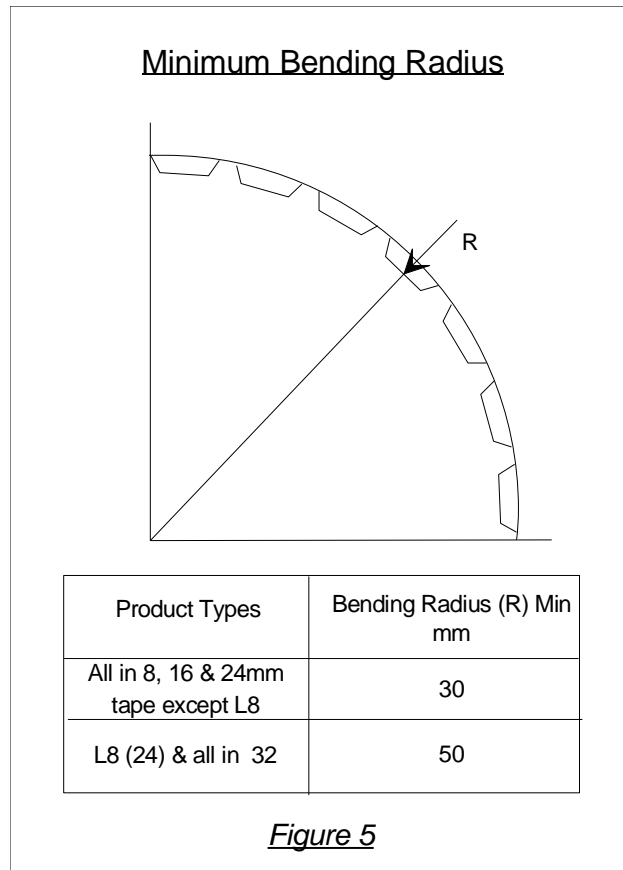

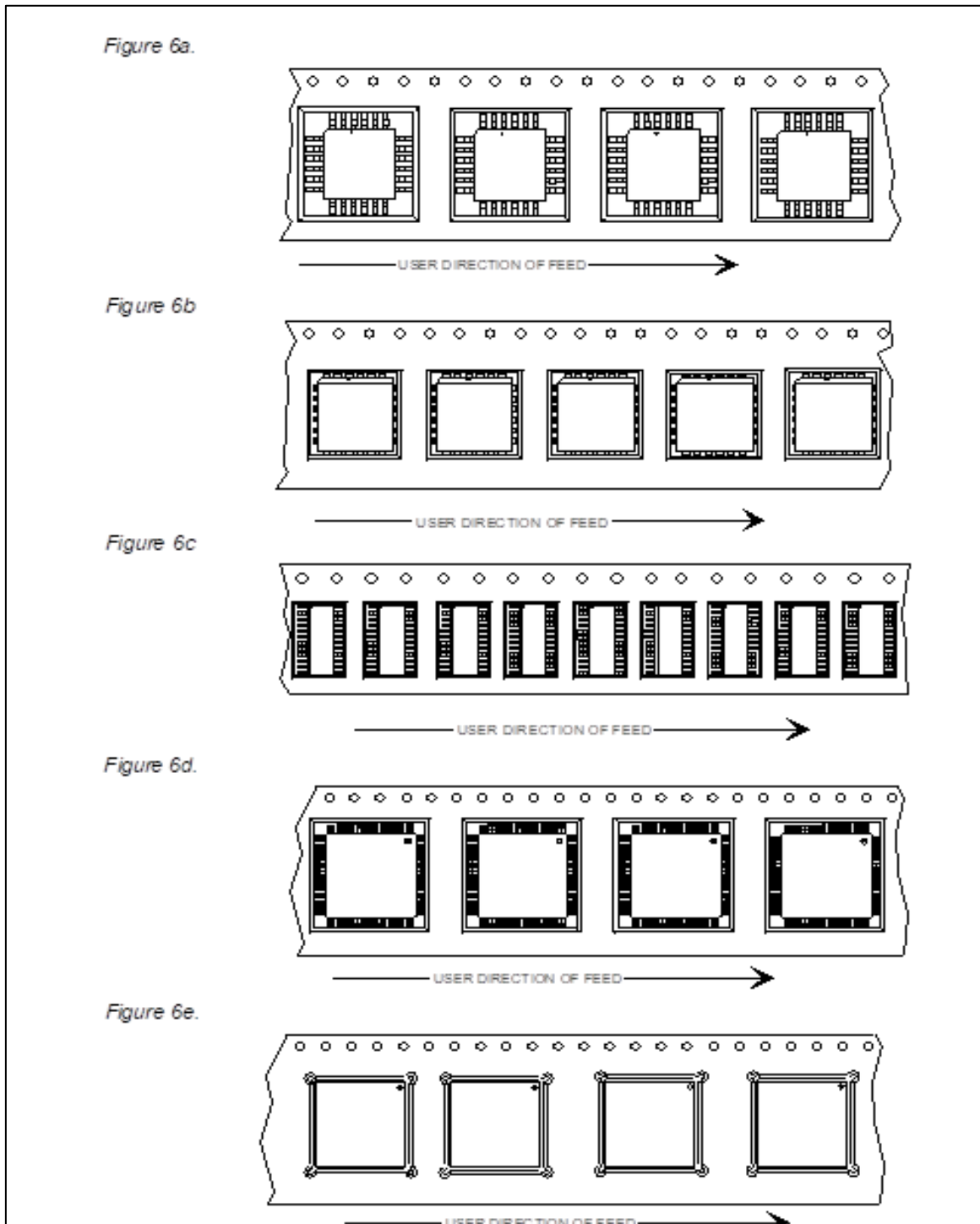

Figure 6. Component Orientation

8 Related Documents

- MQS Pi-34 Devices & Materials for Bake and Dry Packing

9 Machine and File ID

<\\cml.plc\cmluk\QualityAssurance\MQS\mqs\le6\le6.docx>

10 History

Issue 1, Mar 2002	Doc	Initial release
Issue 2, Apr 2004	Doc	S1 package deleted. Drawing 1a removed & 6d modified to remove second row of index holes. L8 package included. Specification style and layout changed
Issue 3, Sep 2005	Section 5.7	Pull strength speed changed from 240 mm to 300 mm per minute.
Issue 4, Nov 2006	Doc	Q1-Q5 (incl) data added. Figure 6 updated to include QFN (6e) Pressure sensitive cover tape removed L9 added
Issue 5, May 2007	Doc	L6 package data included. Fig 6 updated to include 44 Lead PLCC (6f)
Issue 6, Jul 2014	Front sheet	Change of Process Owner
	Doc	Q6 and Q7 packages included.
Issue 7, Jun 2017	Front sheet	Change of Managing Director.
	Doc	Q8 and QT8 packages added. L3 and M1 packages removed.
	Section 5.7	Peel strength was 60 ± 40 grams, now 60 +40/-30 grams.
	Section 6.1	Table 6.1.1:- Tape width was quoted as 8mm in error, should have been 12mm. This affected values for W, W1 and W2.
	Section 6.7	"paper" deleted as it's not always a paper tape used.
Issue 8, Feb 2021	Front sheet	Authorised changed from Managing Director to Operations Manager
	Doc	QT1, QF and T1 packages added.
	Section 6	7"x12mm packaging reel added.
	Section 6.9	Include moisture barrier bags and referenced Pi-34.
Issue 9, Jul 2021	Doc	Reviewed tolerances on dimensions. A4, A7, B1 and QH packages added. Added A4, A7, E1, E2, E3, E4, Q1, QT1, Q2, Q3, Q4, Q5, Q6, Q7, Q8, QT8, QF, QH packages in 1Ku quantities on 7" reels.
Issue 10, Apr 2025	Front sheet	Updated approvers
	Doc	Reformatted & added CML logo following rebranding.
	Doc	Added A6 & QK packages. Removed L1, L2, L6 & L7 packages
	Section 8	Added related documents section
	Section 9	Added file link
Issue 11, Apr 2025	Section 6.2	Added QR code to reel labels