

## 1 Introduction

This application note suggests circuit values for the 450 to 520 MHz band and the 136 to 174 MHz band; it accompanies the existing 400 to 470 MHz operation application note (AN/RF/CMX994A/E 440 to 470) and is based around the CM994A/E evaluation platform (EV9942A/E). The circuit uses a combination of low and high pass filter elements. It is assumed in both cases that the user will have to consider further filtering at the RF front end to meet the  $f_r / 2$  and harmonic spurious responses.

## 2 History

Version	Changes	Date
1.0	New Issue	08-02-18

## 3 Results

### 3.1 EV9942A/E Default values

The EV9942A/E, as built, was investigated over a wide input frequency range. The cascaded chain of the CMX994A/E is shown in Figure 1, all reference designators refer to the EV9942A/E schematic.

The results in Figure 2 show the response of the complete Rx chain with the following common settings:

- Normal IP3 mode
- LO phase correction ON
- Freq cntrl = 300 to 700 MHz
- ACR filter at maximum
- LNA = 50R mode
- IM reg = 63 dec
- Local Oscillator at  $f_r \times 2$  (external LO)

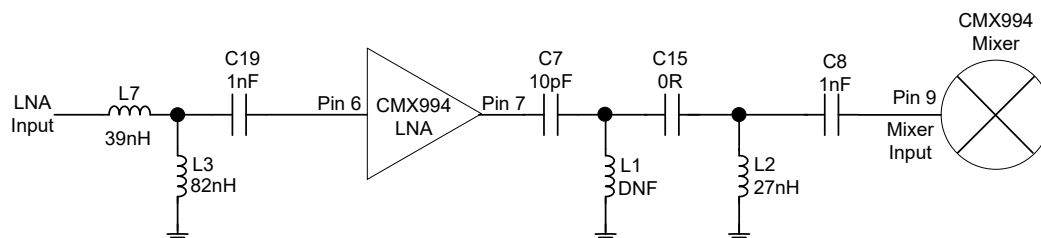

Figure 1 – Default values of the EV9942A/E Rx chain

The gain response in Figure 2 shows that the default matching values cover the 400 to 500 MHz band but doesn't provide much out-of-band filtering. The typical gain variation across the operating band is ~ 1dB.

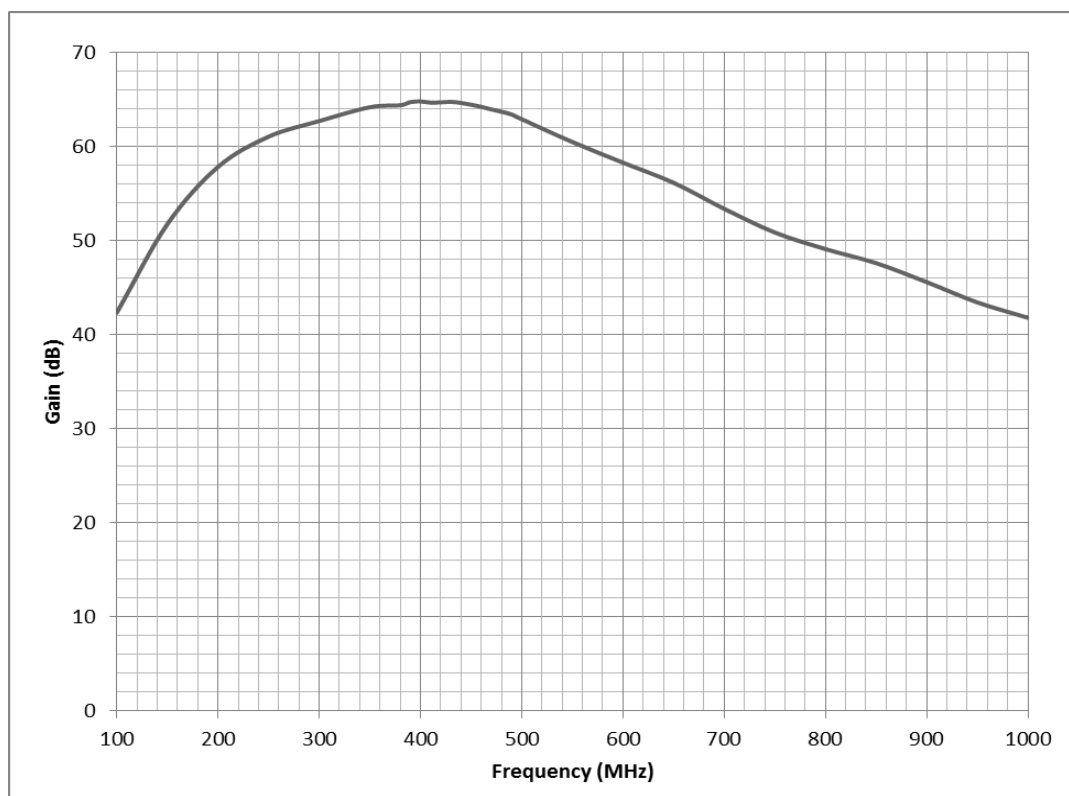
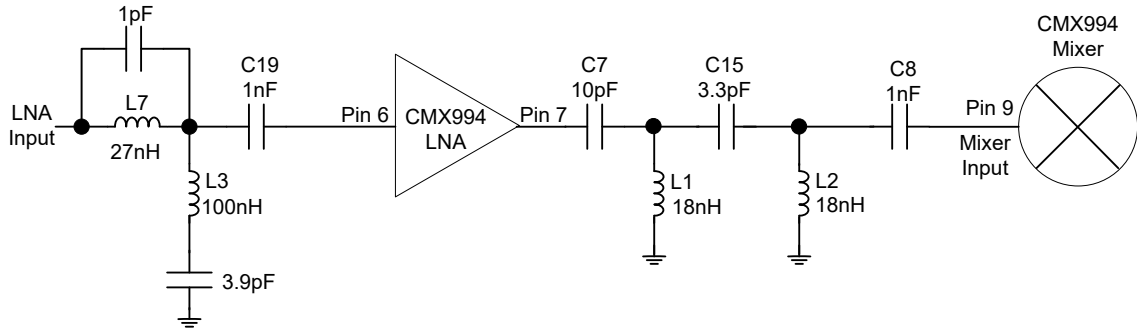

Figure 2 – Gain variation of the default build of EV9942A/E from 100MHz to 1GHz

### 3.2 EV9942A/E Matching Values for 450 to 520 MHz

The following results show a new circuit, as shown in Figure 3, implemented on an EV9942E (note: the same circuit can be used on EV9942A). The changes require slight re-arrangement of components to add in some extra filtering but this is easy to implement, i.e. at position L7 and L3.



**Figure 3 – CMX994A/E 450 to 520 MHz matching circuit**

The gain response with the matching in Figure 3 is shown in Figure 4. The new matching circuit provides rejection of the spurious responses within the LO region and also at the  $f_{rf} / 2$  (e.g. 225 to 260 MHz) which is often a problematic spurious response. A system assumption has been made that there will be further high and low pass filtering prior to the CMX994A/E receiver input for example a common Tx/Rx low pass harmonic filter to provide the LO rejection.

The new matching circuit has a gain variation of <1dB across the 450 to 520 MHz band.

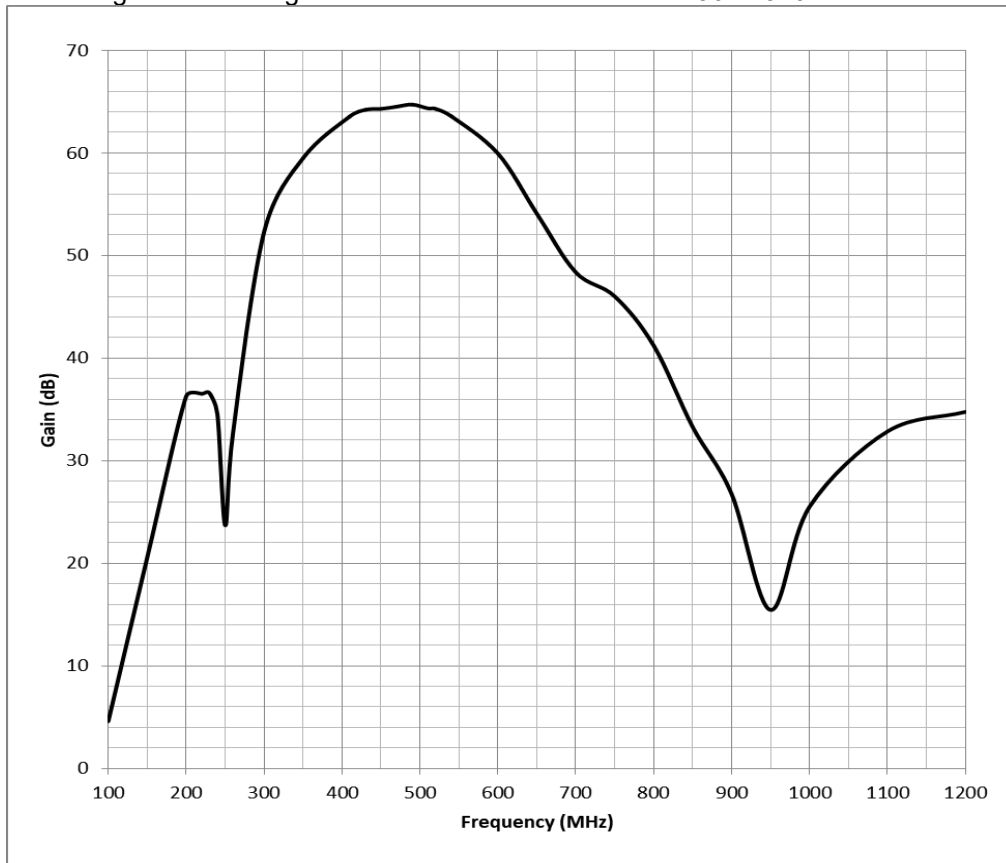

**Figure 4 – EV9942E gain response with new matching values for 450 to 520 MHz operation**

The noise figure of the complete chain is 4.6 to 4.8 dB across the operating band. The  $f_{rf} / 2$  system response needs approximately 15dB more rejection.

### 3.3 EV9942A/E Matching Values for 136 to 174 MHz

The following results show a new circuit, as shown in Figure 5, implemented on an EV9942A/E with the addition of a high pass filter at the input. The high pass filtering at the input to the LNA cannot be easily implemented on the existing EV9942A/E board layout, so for test purposes this was built on an

external board to prove the concept. There is one other change that requires some slight re-arrangement of components to add in some extra filtering but this is easy to implement, i.e. at position L7.

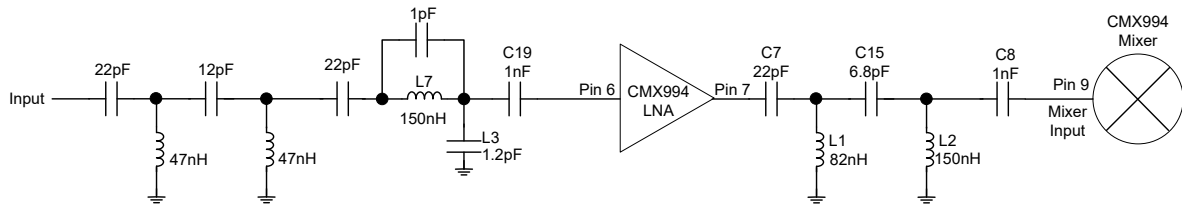

**Figure 5 – CMX994A/E 136 to 174 MHz matching circuit**

At VHF operating frequencies, compared to the 400 to 470 MHz and 450 to 520 MHz bands, the gain is higher (~2 to 3 dB) in LNA 50R mode and this does have an impact on the IIP3 for the complete chain. The gain can be reduced and the IIP3 improved by using the LNA 100R mode. The gain response in both LNA modes, with the Figure 5 matching, is shown in Figure 6. The new matching circuit provides rejection of the spurious responses within the LO region and also at the  $f_{rf} / 2$  (e.g. 68 to 87 MHz) which is often a problematic spurious response. A system assumption has been made that there will be further low pass filtering prior to the CMX994A/E receiver input, for example a common Tx/Rx low pass harmonic filter to provide the LO rejection.

The new matching circuit has a gain variation of circa 1.5dB across the 136 to 174 MHz band in both LNA modes, see Figure 7.

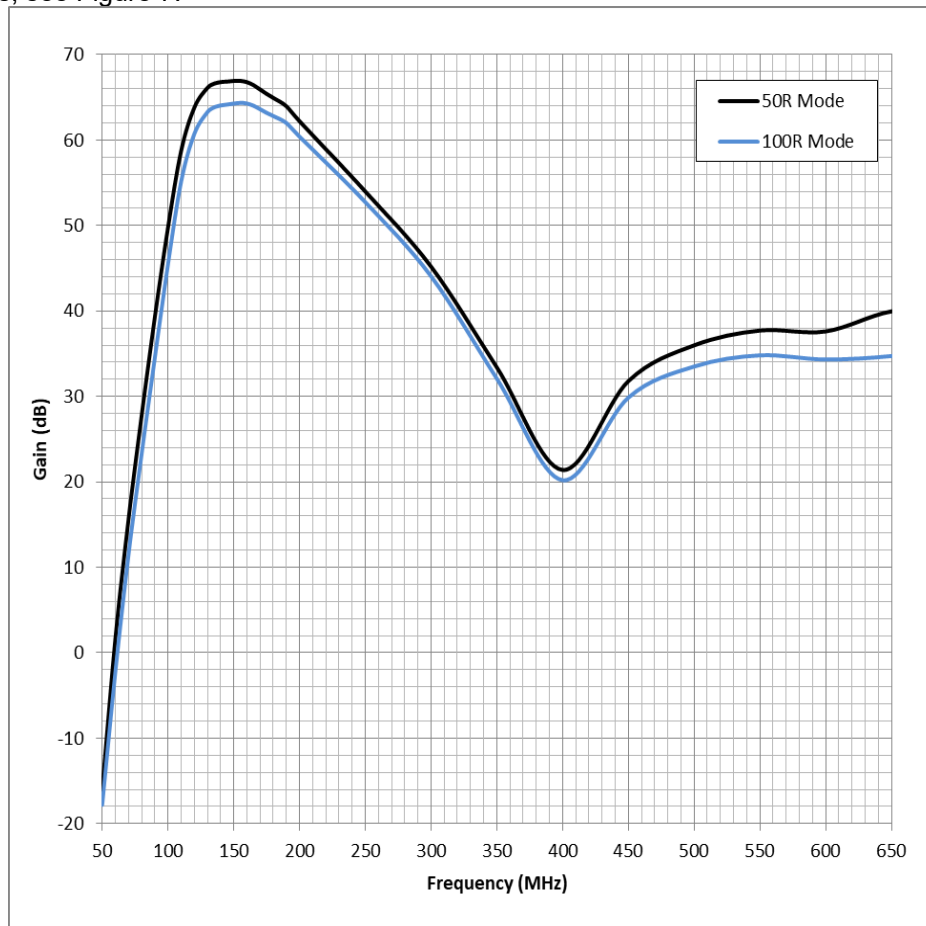

**Figure 6 – EV9942E gain response with matching values for 136 to 174 MHz operation**

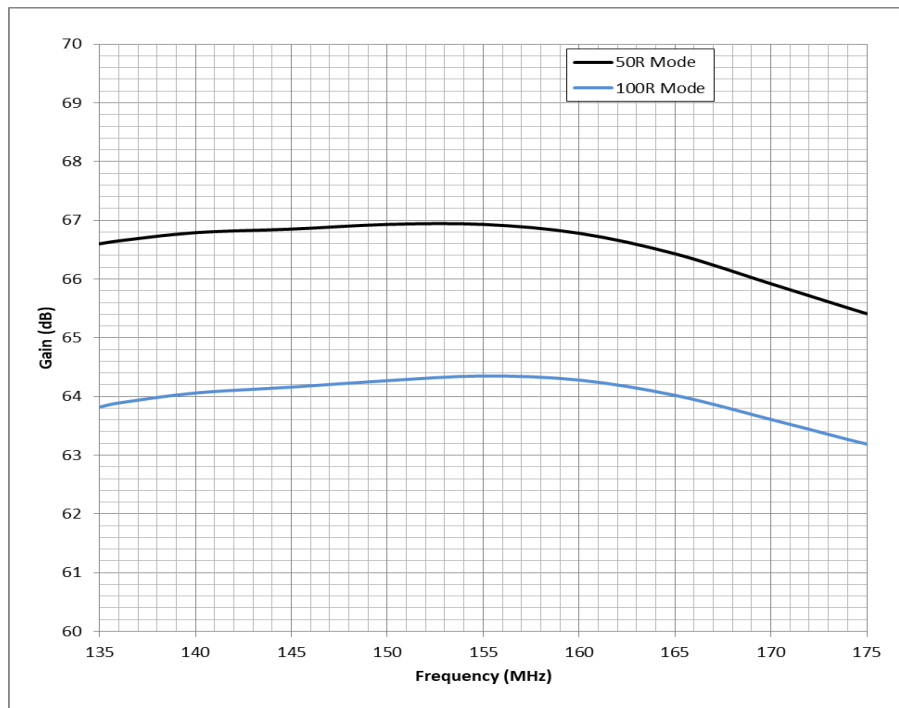

**Figure 7 – Gain variation across the operating band**

In 50R mode the noise figure of the complete chain is 4.4 to 4.8 dB across the operating band and in 100R mode this degrades slightly to 4.8 to 5.2 dB. In 50R mode the IIP3 of the chain at 153MHz (mid band) was measured as -3.3dBm and in 100R mode the IIP3 was measured as -1.3dBm<sup>1</sup>.

The  $f_{ff} / 2$  system response at 87MHz (worst case) looks satisfactory.

A typical set of results using simple test signals can be configured as follows; these wanted and interferer signal levels are typical of the levels used in the EN 300 113 spurious response test.

Wanted signal at 174MHz @ -107dBm gives an output tone level of -40dBm  
 Interferer at 87MHz @ -37dBm<sup>2</sup> gives an output tone level of ~-59dBm

This shows a difference of approximately 19dB between the wanted output level and the resultant spurious created by the interferer.

<sup>1</sup> This value is in line with typical values measured in the range 400 - 520 MHz in 50R mode.

<sup>2</sup> it is important that the 2<sup>nd</sup> harmonic of the interferer is lower than -117dBm as it will act like a co-channel interferer at the input.

## 4 Conclusion

The CMX994A/E can be configured to cover the 450 to 520 MHz and the 136 to 174 MHz operating bands. As is normal practice, customers will need to validate the suggested matching values for a particular PCB layout.

System consideration needs to be given to the total amount of rejection required at certain spurious responses and also that the overall system gain, noise figure and IIP3 will be affected by any Rx front end circuitry like Tx/Rx switching and filtering. Therefore, this application provides a starting point for the whole system design at the frequencies of interest.

CML does not assume any responsibility for the use of any algorithms, methods or circuitry described. No IPR or circuit patent licenses are implied. CML reserves the right at any time without notice to change the said algorithms, methods and circuitry and this product specification. CML has a policy of testing every product shipped using calibrated test equipment to ensure compliance with this product specification. Specific testing of all circuit parameters is not necessarily performed.

 <b>CML Microcircuits (UK) Ltd</b> COMMUNICATION SEMICONDUCTORS	 <b>CML Microcircuits (USA) Inc.</b> COMMUNICATION SEMICONDUCTORS	 <b>CML Microcircuits (Singapore) Pte Ltd</b> COMMUNICATION SEMICONDUCTORS <div style="display: flex; justify-content: space-around;"> <span><b>Singapore</b></span> <span><b>China</b></span> </div>	
<b>Tel:</b> +44 (0)1621 875500 <b>Fax:</b> +44 (0)1621 875600 <b>Sales:</b> sales@cmlmicro.com <b>Tech Support:</b> techsupport@cmlmicro.com	<b>Tel:</b> +1 336 744 5050 800 638 5577 <b>Fax:</b> +1 336 744 5054 <b>Sales:</b> us.sales@cmlmicro.com <b>Tech Support:</b> us.techsupport@cmlmicro.com	<b>Tel:</b> +65 67450426 <b>Fax:</b> +65 67452917 <b>Sales:</b> sg.sales@cmlmicro.com <b>Tech Support:</b> sg.techsupport@cmlmicro.com	<b>Tel:</b> +86 21 6317 4107 +86 21 6317 8916 <b>Fax:</b> +86 21 6317 0243 <b>Sales:</b> cn.sales@cmlmicro.com.cn <b>Tech Support:</b> sg.techsupport@cmlmicro.com
<b>- www.cmlmicro.com -</b>			