



D/228/1 October 1999

Advance Information

Features

- Full ISDN Voice and Data Services
- V.120 / PPP Operation
- Hayes Compatible 'AT' Command Set
- Supports CTR3 Approval
- User Data and X.25 via B and D-channels
- Full API Available

Applications

- Feature Phones with Data Interfaces
- Pay-Phones and H.320 Video Phones
- EPOS Terminals
- Remote Metering and Alarm Systems
- Data Terminal Adapters
- Reference Designs Available

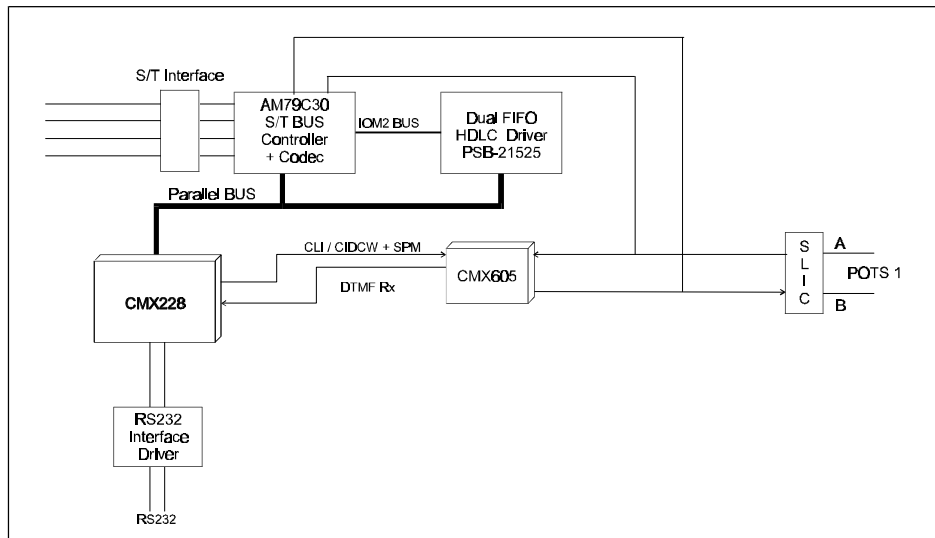

1.1 Brief Description

The CMX228 is an ISDN data and telephony protocol engine which implements the lower level ISDN interface and communicates with the CMX605 and other standard devices to form a fully integrated ISDN chipset for both voice and data communications. It puts all the main data processing elements in one device, no ISDN software has to be written and simple 'Plug and Play' design results. The CMX228 supports one voice port, which can be used to provide ISDN telephony services or a POTS line interface, and one data channel, capable of operation at 115,200 b/s. It also has a full set of 'Hayes' compatible AT command codes on its asynchronous data interface and keypad-configurable voice telephony services.

The CMX228 is designed to work with the AMD 79C30 S/T bus interface, the Siemens PSB-21525 HDLC formatter and the CML CMX605 POTS interface circuit, and also comes complete with embedded applications software. In addition, the CMX228 offers data transfer (up to 16kb/s) over the D-channel by using the X.25 protocol. To support the CMX228, CML can also provide licensed reference designs on user request. A flexible Applications Program Interface (API) allows users to customise the features and operation of their own design. The CMX228 comes in a compact 80-pin surface mount package.

CONTENTS

<u>Section</u>	<u>Page</u>
1.0 Features and Applications	1
1.1 Brief Description.....	1
1.2 Block Diagram	4
1.3 Signal List.....	5
1.4 External Components.....	8
1.5 General Description.....	9
1.5.1 Glossary	10
1.5.2 Initialisation	11
1.5.3 ISDN Interface.....	11
1.5.3.1 Activation	11
1.5.3.2 De-activation or Line Disconnection	11
1.5.3.3 Line Failure Detection	11
1.5.3.4 Incoming Calls	12
1.5.3.5 Multiple Subscriber Numbering.....	12
1.5.3.6 Channel Mapping.....	12
1.5.4 POTS Configuration.....	13
1.5.4.1 Configuration and Control via DTMF Keypad.....	13
1.5.5 POTS Operation	15
1.5.5.1 Keypad Operation	15
1.5.5.2 Incoming POTS Calls.....	15
1.5.5.3 Outgoing POTS Calls.....	15
1.5.5.4 Connected Calls.....	16
1.5.5.5 Call Clearing	16
1.5.6 Data Configuration.....	17
1.5.6.1 Hayes Command Set.....	17
1.5.6.2 Hayes Register Set.....	22
1.5.6.2.1 X.25 Virtual Circuit Parameters	23
1.5.6.2.2 X.25 Parameters.....	24
1.5.6.2.3 V.120 Parameters	25
1.5.6.2.4 X.25 PAD Parameters.....	25
1.5.6.2.5 B Channel LAPB Parameters	26
1.5.6.2.6 Basic Configuration Parameters	26
1.5.7 Data Operation	28
1.5.7.1 Incoming B-Channel Data Calls.....	28
1.5.7.2 Outgoing B-Channel Data Calls.....	28
1.5.7.3 X.25 Data Calls on the D-Channel.....	28
1.5.7.4 Connected Calls.....	28
1.5.7.5 Call Clearing	28
1.5.8 Application Programmer's Interface	29
1.5.9 Hardware Description	30
1.5.9.1 LED Status Indicators (LED1 to LED9, and ILFI).....	30

1.6 Application Notes	31
1.6.1 General	31
1.6.2 Approvals	31
1.7 Performance Specification	32
1.7.1 Electrical Performance	32
1.7.1.1 Absolute Maximum Ratings	32
1.7.1.2 Operating Limits	32
1.7.1.3 Operating Characteristics	33
1.7.2 Packaging	38

Note: This product is in development: Changes and additions will be made to this specification. Items marked TBD or left blank will be included in later issues.

Information in this data sheet should not be relied upon for final product design.

1.2 Block Diagram

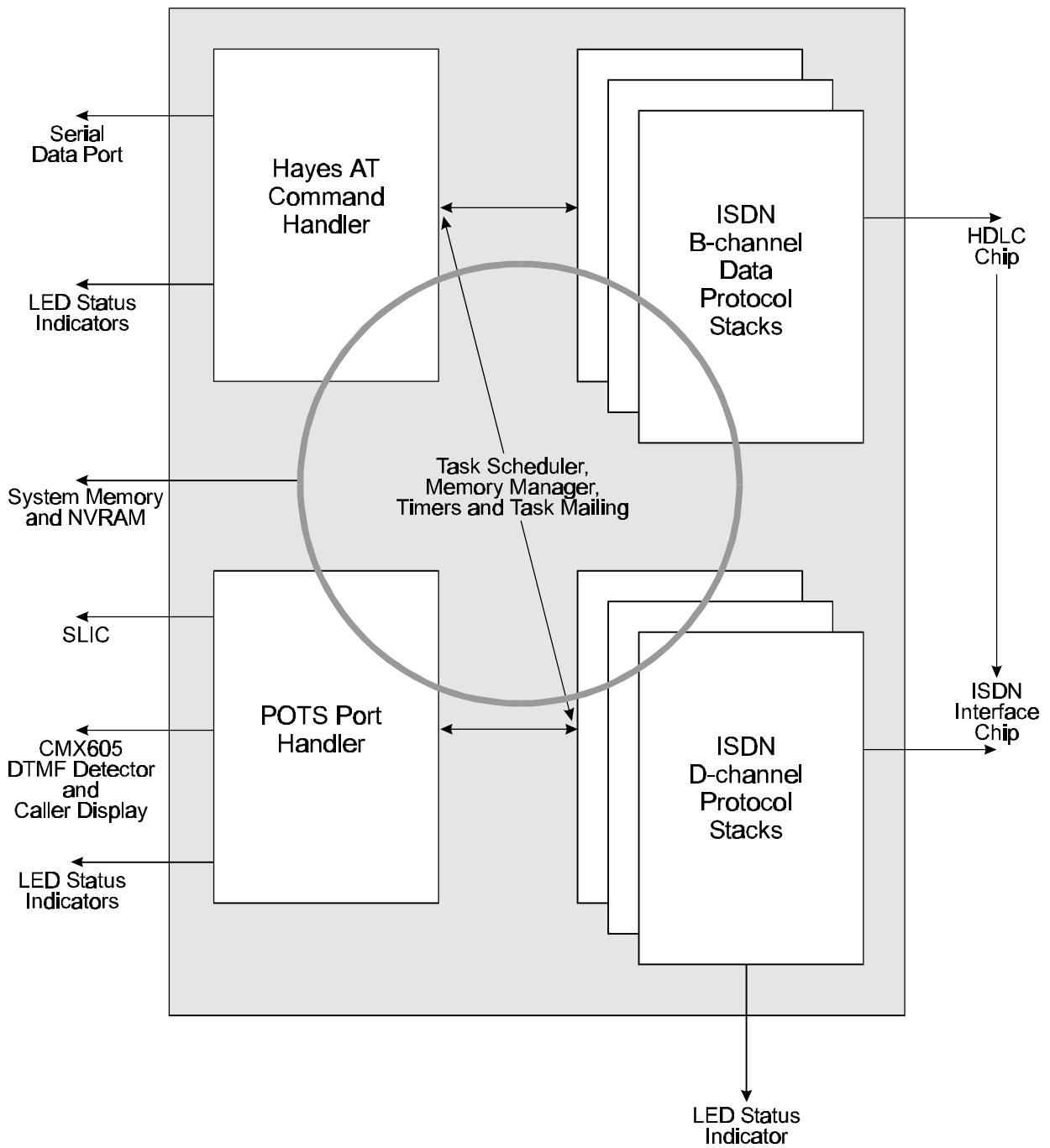

Figure 1 Block Diagram

1.3 Signal List

S1 Package 80QFP		Signal		Description
Pin No.	Name	Type		
1	SCL	O/P		EEPROM - Serial Clock
2	SDA	BI		EEPROM - Serial Data
3	ISDNRST	O/P		ISDN S-interface Chip Reset
4	RI1	O/P		RS232 Port1 Ring Indicator (high when inactive)
5	DCD1	O/P		RS232 Port1 Data Carrier Detect (high when inactive)
6	CTS1	O/P		RS232 Port1 Clear To Send (high when inactive)
7	RSTN	I/P		CMX228 Chip Reset (active low)
8	DV _{DD1}	Power		The digital positive supply rail. Levels and voltages are dependent upon this supply. This pin should be decoupled to DV _{SS} by a capacitor
9	XTALN	O/P		The output of the on-chip Xtal oscillator inverter
10	XTAL	I/P		The input to the oscillator inverter from the Xtal circuit
11	DV _{SS1}	Power		The digital negative supply rail (ground)
12	LED1	O/P		POTS Port Off-Hook Indicator (HK1)
13	LED2	O/P		RS232 Port 1 Auto-Answer Indicator (AA)
14	LED3	O/P		RS232 Port 1 Data Carrier Detect Indicator (DCD)
15	LED4	O/P		RS232 Port 1 Ready To Send Indicator (RTS)
16	LED5	O/P		RS232 Port 1 Receive Data Indicator (RXD)
17	LED6	O/P		RS232 Port 1 Transmit Data Indicator (TXD)
18	LED7	O/P		RS232 Port 1 Data Terminal Ready Indicator (DTR)
19	LED8	O/P		ISDN Line Activated Indicator (AR)
20	STN	O/P		Watchdog Timer Stimulus
21	LED9	O/P		POTS Port Call Connected Indicator (CN1)
22	WRN	O/P		Memory Write Access Strobe
23	RDN	O/P		Memory Read Access Strobe
24	A19	O/P		Memory and Peripheral Address Bus
25	A18	O/P		Memory and Peripheral Address Bus
26	A17	O/P		Memory and Peripheral Address Bus
27	A16	O/P		Memory and Peripheral Address Bus
28	A15	O/P		Memory and Peripheral Address Bus

S1 Package 80QFP		Signal		Description
Pin No.	Name	Type		
29	A14	O/P		Memory and Peripheral Address Bus
30	A13	O/P		Memory and Peripheral Address Bus
31	A12	O/P		Memory and Peripheral Address Bus
32	A11	O/P		Memory and Peripheral Address Bus
33	A10	O/P		Memory and Peripheral Address Bus
34	A9	O/P		Memory and Peripheral Address Bus
35	A8	O/P		Memory and Peripheral Address Bus
36	A/D7	BI		Memory and Peripheral Address and Data Bus
37	A/D6	BI		Memory and Peripheral Address and Data Bus
38	A/D5	BI		Memory and Peripheral Address and Data Bus
39	A/D4	BI		Memory and Peripheral Address and Data Bus
40	A/D3	BI		Memory and Peripheral Address and Data Bus
41	A/D2	BI		Memory and Peripheral Address and Data Bus
42	A/D1	BI		Memory and Peripheral Address and Data Bus
43	A/D0	BI		Memory and Peripheral Address and Data Bus
44	ASTB	O/P		Address/Data Bus Strobe (data bus selected if low)
45	DV _{SS0}	Power		The digital negative supply rail (ground)
46	~	I/P		For manufacturer's use only. Connect to DV _{SS} directly
47	PSBRES	O/P		HDLC Chip Reset
48	N/C	O/P		Do not make any connection to this pin
49	N/C	O/P		Do not make any connection to this pin
50	API-RXD	I/P		API/RS232 Port 2 Rx Data (inactive = high)
51	API-TXD	O/P		API/RS232 Port 2 Tx Data (high when inactive)
52	N/C	O/P		Do not make any connection to this pin
53	NC	O/P		Do not make any connection to this pin
54	ILFI	O/P		ISDN Line Failure Indicator
55	DV _{DD0}	Power		The digital positive supply rail. Levels and voltages are dependent upon this supply. This pin should be decoupled to DV _{SS} by a capacitor
56	RINGP1	O/P		POTS Port Ringing Generator (low when not ringing)
57	RINGN1	O/P		POTS Port Ringing Generator (high when not ringing)

S1 Package 80QFP		Signal		Description
Pin No.	Name	Type		
58	CLIP1	O/P		POTS Port Line Voltage Adjustment (low if sending FSK to a Caller Display unit, as it is intended to make the SLIC present a high impedance to the POTS line)
59	ILINE1	I/P		POTS Port Hook Switch Status Detector (on-hook = low)
60	~	I/P		For manufacturer's use only. Connect to DV _{SS} directly
61	REPLY	I/P		CMX605 C-BUS Interface - Reply Data
62	CMD-DATA	O/P		CMX605 C-BUS Interface - Command Data
63	SER-CLK	O/P		CMX605 C-BUS Interface - Serial Clock
64	AV _{DD}	Power		The positive analogue supply rail. Levels and voltages are dependent upon this supply. This pin should be decoupled to AV _{SS} by a capacitor
65	AV _{REF1}	Power		A/D Reference Voltage. Connect to AV _{DD} directly
66	AV _{SS}	Power		The negative analogue supply rail (ground)
67	CSN1	O/P		CMX605 C-BUS Interface (chip select for POTS Port)
68	N/C	O/P		Do not make any connection to this pin
69	AV _{REF2}	Power		D/A Reference Voltage. Connect to AV _{DD} directly
70	AV _{REF3}	Power		D/A Reference Voltage. Connect to AV _{SS} directly
71	NMI	I/P		For manufacturer's use only. Connect to DV _{SS} directly
72	API-INT	I/P		API Interrupt (inactive = high)
73	IRQN	I/P		CMX605 C-BUS Interface - Interrupt (inactive = high)
74	PSBINT	I/P		HDLC Chip Interrupt
75	RXD1	I/P		RS232 Port 1 Received Data - used for autobauding
76	RTS1	I/P		RS232 Port 1 Ready To Send (inactive = high)
77	ISDNINT	I/P		ISDN S-interface Chip Interrupt
78	DTR1	I/P		RS232 Port 1 Data Terminal Ready (inactive = high)
79	RXD1	I/P		RS232 Port 1 Received Data (inactive = high)
80	TXD1	O/P		RS232 Port 1 Transmitted Data (high when inactive)

Notes: I/P = Input
O/P = Output
BI = Bidirectional

1.4 External Components

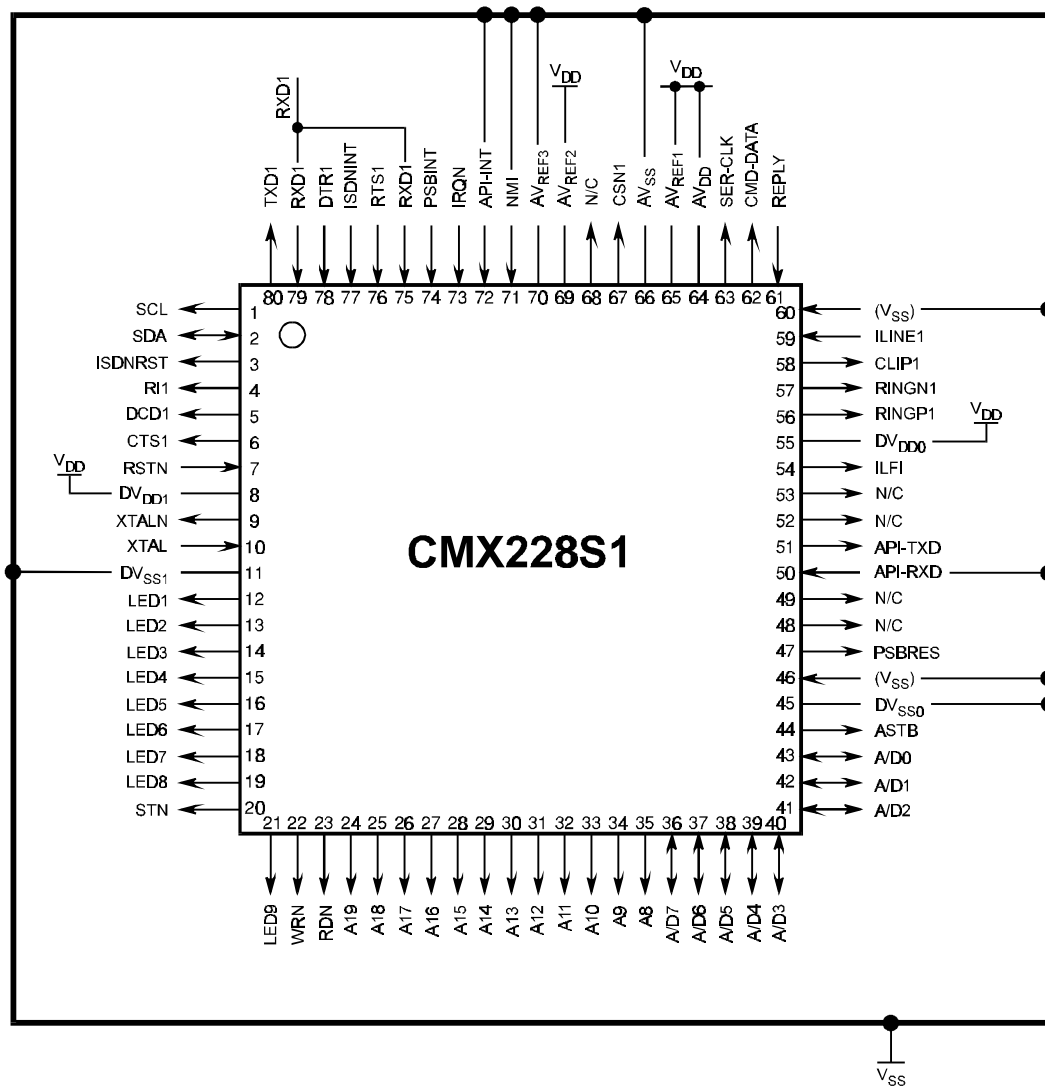

Note: This product is to be used as part of a chip-set. Please refer to the Applications Section (section 1.6) for details of the recommended chip-set.

Figure 2 CMX228 Pinout

1.5 General Description

The CMX228 is a single-chip data processor which has been mask programmed with firmware to implement an ISDN protocol stack. This enables the CMX228 to provide an analogue (POTS) port and a digital (RS232) port with an ISDN S-bus network connection. Key variables are stored in an external EEPROM and the user can provide additional features by adding external ROM and RAM. Access to the firmware Application Programmer's Interface (API) facilitates the seamless integration of the user's additional features with the pre-programmed ISDN to POTS and RS232 interfaces.

The CMX228 is intended for use as part of an ISDN chipset and all descriptions in this data sheet refer to this implementation, which is shown diagrammatically in Figure 3. The use of alternative chipsets is not supported.

The firmware supports connection to an ISDN S-bus network interface via the Siemens PSB21525 HDLC controller and the AMD AM79C30 ST controller with integral PCM codec for a single POTS port.

The CMX228 interfaces with a CMX605 Tone Generator and DTMF Receiver chip, which decodes incoming DTMF tones and generates call progress signals (eg busy tone) normally originating from an analogue telephone exchange. The firmware translates the CMX605 data into ISDN D-channel commands and vice versa to support both incoming and outgoing calls. For the ISDN interface, D-channel commands sufficient for standard telephony applications are implemented. With the aid of a small amount of discrete circuitry, exchange battery voltage, ringing current, line reversal and off-hook detection are also supported, to complete the POTS interface.

The CMX228 also provides a data port which can drive a standard RS232 interface with the aid of a Maxim MAX238, or similar, level converter. The firmware provides support for incoming and outgoing data calls, RS232 auto-bauding from 9600bps to 115200bps, auto parity detection, RTS/CTS flow control, call clearing on loss of DTR, V.120 rate adaption, PPP async to sync conversion, X.25 protocol on both B and D-channels, packet assembly and disassembly for X.25, and a comprehensive set of Hayes commands (which facilitate the use of normal PC-based modem software). The CMX228 has dedicated outputs for visible indicators (LEDs) which can be used to provide information on the call status. Support for Multiple Subscriber Numbering is also included in the firmware.

The CMX228 can be configured either by means of keypad (DTMF) programming via the POTS port or by means of an extended Hayes command set via the RS232 port. Configuration parameters allow the user to change (for example) the format and cadence of the ringing signal, so as to facilitate use of the CMX228 in different countries. Each POTS and RS232 interface is able to configure the variables relevant to its own use.

An Application Programmer's Interface (API) is available and is described separately in section 1.5.8. Further details are available on completion of a Non-Disclosure Agreement. Please contact CML Sales directly for further details.

The firmware and finite state machine embedded in the CMX228 have been used in products which have gained ETSI CTR3 approval.

1.5.1 Glossary

ACCM	Asynchronous Control Character Map
API	Application Programmer's Interface
CIDCW	Caller Identification During Call Waiting
CLI	Calling Line Identification
CRC	Cyclic Redundancy Check
CTS	Clear to Send
DCD	Data Carrier Detect
DDI	Direct Dialling Inwards
DTE	Data Terminal Equipment
DTMF	Dual Tone Multiple Frequency
DTR	Data Terminal Ready
HDLC	High Level Data Link Control
IA5	International Alphabet No 5
IE	Information Element
ILFI	ISDN Line Failure Indicator
ISDN	Integrated Services Digital Network
LAPB	Link Access Procedure - Balanced
LAPD	Link Access Procedure on the D-Channel
LCGN	Logical Channel Group Number
LED	Light Emitting Diode
LLI	Logical Link Identifier
MFO	Multiple Frame Operation
MSN	Multiple Subscriber Numbering
NU	Number Unobtainable
NUA	Network User Address
NUI	Network User Identification
PAD	Packet Assembler/Disassembler
PC	Personal Computer
PCM	Pulse Code Modulation
POTS	Plain Old (Analogue) Telephone Service
PPP	Point to Point Protocol
PVC	Permanent Virtual Circuit
RI	Ring Indication
RNR	Receiver Not Ready
RR	Receiver Ready
RTS	Ready to Send
SABM	Set Asynchronous Balanced Mode
SABME	Set Asynchronous Balanced Mode Extended
SLIC	Subscriber Line Interface Circuit
SPM	Subscriber Pulse Metering
SVC	Switched Virtual Circuit
TEI	Terminal Endpoint Identifier

1.5.2 Initialisation

On power-up, the CMX228 assumes its default values, which are factory programmed into the firmware. It then performs a self-test, during which all of the LED pins and the ILFI pin are held high for 3s. If the test is unsuccessful, the CMX228 remains in this condition.

If the test is successful, the CMX228 reads its preset values from the attached EEPROM and examines the state of the ISDN link (ie Layer 1) before commencing normal operation. On power-up, the ISDN link is de-activated, the POTS port is assumed to be on-hook, ringing is disabled and the RS232 port is in the Hayes command state.

1.5.3 ISDN Interface

Simultaneous voice and data calls are possible but only one of each type. If a call is active (eg ringing, connected or clearing down) and an incoming call of the same type (data or voice) is received, that call will be rejected with user busy as the cause. Incoming calls are firstly checked for other calls present, then the MSN is checked for validity, then the channel mapping, so that responses will be handled accordingly.

When channel mapping is enabled, outgoing calls will request the channel enabled. When not enabled, a request for any channel is made. If no free channels are available for outgoing calls, a locally generated busy tone is returned to the analogue port or the appropriate Data Call Result Code is returned to the digital port.

1.5.3.1 Activation

Activation occurs in the following circumstances:

- The ISDN network activates.
- The device connected to the analogue port goes off hook.
- The device connected to the data port sends a Hayes dial command.

The Terminal Endpoint Identifier (TEI) is either negotiated (Hayes register !C7 = 64) or fixed (Hayes register !C7 = 0 to 63). Line powering of the CMX228 is not supported.

The 'AR' indicator (LED8) toggles between high and low states when the CMX228 is powered up, and remains constantly low once the CMX228 identifies an activated ISDN line.

ISDN line power detection is not implemented and the CMX228 will negotiate a new TEI on any new network activation.

1.5.3.2 De-activation or Line Disconnection

De-activation or line disconnection causes the TEI to be removed. Upon re-connection the CMX228 will only be re-activated and request a new TEI when one of the conditions in the above section is met.

1.5.3.3 Line Failure Detection

If the line failure detection parameter is enabled (either via the POTS port or via the RS232 interface) the CMX228 will check that Layer 2 communications are active every sample period of 30 seconds. If Layer 2 communications are not active, the CMX228 will attempt to activate them. If they remain inactive for 2 sample periods, the line is deemed to have failed, so then the ILFI pin is set high. The CMX228 continues to attempt to activate the line and if it becomes active and stays active for 2 sample periods, then the ILFI pin is set low.

1.5.3.4 Incoming Calls

Incoming voice calls and calls from analogue lines are directed to the analogue port and all other incoming calls are directed to the RS232 port.

1.5.3.5 Multiple Subscriber Numbering

Multiple Subscriber Numbering (MSN) enables each POTS or RS232 port of the CMX228 to have its own telephone number. Up to 23 digits can be saved as the MSN for each port.

All incoming SETUP messages will be checked for the presence of a Called Party Number Information Element (IE). If one is present it is compared with the saved MSN number (if present), starting with the last digit of both numbers. Comparison continues until there are no more numbers in the MSN saved number or the incoming Called Party Number or there is a difference between the numbers. The MSN is said to match if the saved MSN and the incoming calls' Called Party Number are the same for the duration of the shorter number (ie if the digit '1' is saved and the received Called Party Number is 654321, then the MSN matches). If there is no saved MSN, the Called Party Number is ignored and call processing continues.

When there is a saved MSN and the Calling Party Number transmit is enabled, all outgoing call SETUP messages will contain a Calling Party Number Information Element.

Note 1: When a CMX228 with MSN saved and Calling Party Number transmit enabled is connected to some exchanges, no dial tone is heard when going off-hook.

Note 2: Disabling the Calling Party Number transmit will mean that the called party may not receive the Calling Line Identification (CLI), or if they do receive a CLI it will probably be the base number and not the number specific to the calling telephone.

1.5.3.6 Channel Mapping

It is possible to configure the CMX228 so that analogue and/or digital ports will only originate calls to and respond to calls from a specific ISDN B-channel. This is a useful feature if, for example, you wish to have a hunt group on your ISDN line (ie to select the next available channel) and only want one voice port to ring on an incoming call.

1.5.4 POTS Configuration

1.5.4.1 Configuration and Control via DTMF Keypad

Configuration can be carried out at any time by causing the POTS port to go off-hook and then immediately entering a configuration sequence of DTMF tones. The sequence signalled to the CMX228 will determine the configuration to be performed, as shown in the following table.

Configuration Sequence	Name	Description	Default
▲02▲#	Test watchdog	Puts the CMX228 into a permanent loop, not updating the external watchdog counter, so after 2s it should reset.	n/a
▲81▲#	Disable CLI delivery on port	Inhibits CLI delivery on the analogue POTS port	n/a
▲81▲1n#	Use V23 FSK for CLI delivery	Configures modem standard to be used for CLI delivery. n = alert mode 0 = FSK follows ring burst as per ETS 300 659-1 para. 6.1.1 1 = FSK follows dual tone alert as per ETS300 659-1 para. 6.1.2.a 2 = FSK follows ringing pulse alert as per ETSI 300 659-1 para. 6.1.2.b 3 = FSK follows line reversal and tone alert as per ETSI 300 659-1 para. 6.1.2.c and BT SIN227.	Disabled
▲81▲2#	Use Bell 202 FSK for CLI delivery	Configures modem standard to be used for CLI delivery. FSK follows ring burst as per Bellcore GR-30-CORE and SR-TSV-002476	Disabled
▲90▲#	Clear MSN	Clears any saved digits	n/a
▲90▲n#	Save Multiple Subscriber Number (MSN)	n = MSN (up to 23 digits)	Clear
▲93▲#	Clear country code	Country code is set to UK by default	n/a
▲93▲n#	Change country code	n = country code 0 = UK 1 = Belgium 2 = Rest of Europe	UK
▲94▲#	Clear channel mapping	Incoming calls on any channel are accepted (provided other parameters are valid eg MSN).	n/a
▲94▲n#	Enable channel mapping	Where n = 1 or 2 for the appropriate channel.	No channel map

Configuration Sequence	Name	Description	Default
◆95◆#	Disable Calling Party No. transmit	Outgoing call SETUP messages do not contain any Calling Party Number Information Elements.	n/a
◆95◆1#	Enable Calling Party No. transmit	Outgoing call SETUP messages contain Calling Party Number Information Element with number set to saved MSN (if a number is present).	Enabled
◆96◆#	Disable DDI transmit	Prevents digits being transmitted to the POTS port upon call connection.	n/a
◆96◆1#	Enable DDI transmit	Upon connection of a call on the POTS port, if there was a Called Party Number Information Element present in the incoming call setup message, the digits are sent as DTMF tones to the POTS port.	Disabled
◆97◆#	Disable line failure detection	Once the CMX228 is de-activated it stays de-activated until the network re-activates it or an outgoing call needs to be made.	n/a
◆97◆1#	Enable line failure detection	The CMX228 checks to see if the ISDN line is activated and Layer 2 communications can be made. It then sets the ILFI pin accordingly.	Disabled
◆9◆◆1234567890#	Initialise all configurations.	Resets all of the configuration variables back to their default values.	n/a

The extent to which full CLI information is delivered to the POTS port will depend upon the CLI facilities which have been implemented on the ISDN network.

Once the '◆' has been recognised, each digit pressed is then checked for validity as a configuration sequence. If any digit pressed is not a valid configuration digit, all digits pressed so far will be transmitted to the network in INFORMATION messages as Keypad Information Elements, until a '#' is entered (with the exception of '◆#' being entered, see Keypad Operation below). If the first four digits received are a valid configuration sequence then the configuration mode is entered. When a valid configuration has been completed the CMX228 will send a single DTMF tone to the POTS port. If a valid configuration sequence is received but subsequent digits are invalid, then subsequent digits entered will be ignored and two DTMF tones will be sent to the POTS port.

If the port goes on-hook part way through configuration, it will cause any digits received so far to be ignored. Configurations can be performed consecutively with the exception of the test function (where the attached handset must be replaced immediately after the configuration has been audibly signalled to the POTS port). All configurations entered will be retained after a power-down as they are stored in the external EEPROM.

1.5.5 POTS Operation

1.5.5.1 Keypad Operation

The CMX228 supports ISDN keypad messages for control of Network Supplementary services either before or during call establishment. When dialling a number (ie off-hook and dial tone audible on POTS port), or if a call has been disconnected by the network but the POTS port has not yet gone on-hook, any keypad string entered will be sent to the network as 'Keypad Information Elements' within INFORMATION messages. Keypad strings are defined as the following sequences of digits, with the exception of the configuration strings defined in the previous section:

◆...#
◆#...#
#...#

When a call is connected, pressing the recall key results in all subsequent key presses being sent to the network as 'Keypad Information Elements' within INFORMATION messages, until the handset is replaced. The tones generated by the key presses are also passed down the B-channel, so the remote user will be able to hear them.

1.5.5.2 Incoming POTS Calls

An incoming POTS call is identified by the Bearer Capability Information Element of the SETUP message being set to 'Speech' or '3.1 kHz Audio'. The call will be routed to the POTS port if it satisfies the following three conditions:

- The port is on-hook.
- The MSN saved for the port matches the Called Number in the incoming SETUP message, or no MSN is specified for the port, or there is no Called Number in the SETUP message. See section 1.5.3.5 for details of POTS port MSN selection.
- The ISDN B-channel on which the call is placed (as indicated in the SETUP message) is compatible with the channel mapping configuration for the port. See section 1.5.3.6 for details of POTS port channel mapping selection.

When the call is routed to the port, the ringing signal for that port will be applied by means of the RINGP1 and RINGN1 pins.

The call is answered when the port with ringing signal goes off-hook. The ringing signal is then stopped and the ISDN call is connected to that port.

1.5.5.3 Outgoing POTS Calls

Outgoing calls are initiated when the POTS port goes off-hook. An ISDN SETUP message is sent to the network with the Bearer Capability Information Element set to 'Speech'. The dial tone presented by the network on that ISDN B-channel which was selected by channel mapping (see section 1.5.3.6), will be routed to the POTS port.

When DTMF tones are received from the POTS port, they are sent to the network either as Called Party Number or Keypad Information Elements. Keypad Information Elements are discussed in section 1.5.5.1.

Receipt of a valid DTMF tone will prompt its conversion to IA5 coded digits, as shown in the following table (IA5 hex digits are in brackets). If the first valid digit to be received is a '◆' then the configuration mode is entered and subsequent digits will be monitored and saved as indicated in section 1.5.4.1. If the first tone received is not a '◆' or '#' (see section 1.5.5.1) that digit and all subsequent digits will be passed to the network in an INFORMATION message as a Called Party Number Information Element.

Digits received before the network has returned the SETUP ACK message are saved. Upon receipt of the SETUP ACK any saved digits will be transmitted.

The DTMF tone mapping is as shown below:

Low Group (Hz)	High Group (Hz)			
	1209	1336	1477	1633
697	1 (31)	2 (32)	3 (33)	A (not used)
770	4 (34)	5 (35)	6 (36)	B (not used)
852	7 (37)	8 (38)	9 (39)	C (not used)
941	♣ (2A)	0 (30)	# (23)	D (not used)

Once the network has indicated that the full number has been received, no further digits will be sent to the network. All tones and announcements from the network (eg ringing, NU, busy etc) and audio (if the call is connected) will be routed to the POTS port, until that port goes on-hook.

1.5.5.4 Connected Calls

Once a call is connected to the analogue port, whether it was incoming or outgoing, a LED indicator pin is set high to indicate that the call is connected. See section 1.5.9.1 for details of the LED indicator pins. Once the call is disconnected, either by receipt of a DISCONNECT message from the network or an on-hook indication, that LED indicator pin is set low.

During a call, if a Recall (ie a line break of appropriate length) is received from the POTS port, the CMX228 will start to look for DTMF tones received on the POTS port. Any tones received will then be sent to the network in ISDN INFORMATION messages, as Keypad Information Elements.

1.5.5.5 Call Clearing

The call is cleared either by the port going on-hook or by the ISDN network. Note that the ISDN B-channel which was being used is not released until the POTS port has gone on-hook.

1.5.6 Data Configuration

1.5.6.1 Hayes Command Set

The following Hayes commands are supported:

A	- Answers a call
D	- Dial
E	- Echo Hayes commands or not
H	- Hang-up
I3	- Firmware part number
Q	- Result code display
V	- Result code form
X	- Result code set
&C	- Carrier detect
&D	- Data terminal ready
&F	- Load factory default
&K	- Flow control
&V	- View active and stored profiles
&Z	- Store directory number

Valid Hayes commands are responded to with an 'OK' result code. Invalid commands are rejected with an 'ERROR' result code.

If when entering an AT command, no command or register name suffix is supplied, a suffix of zero is assumed. If when changing a register value, no value is supplied a value of zero or an empty string is assumed: eg `ATS0=<CR>` is equivalent to `ATS0=0<CR>`.

If a data call is active when a command is entered, the command will be processed. The ATO command will respond 'OK', but will not then enter the data state: it will stay in the command state.

Where commands set a parameter, these are saved in external EEPROM if they are entered correctly.

The CMX228 will auto-baud and auto-parity on Hayes commands at the following speeds:

9600 bps
19200 bps
38400 bps
57600 bps
115200 bps

The auto-bauding process looks for the characters 'AT' or 'at' either as 8 bits no parity or 7 bits even, or odd, parity. An error in the auto-bauding process results in auto-bauding being restarted.

After auto-bauding successfully, the CMX228 waits to receive a complete Hayes command line before processing it. Embedded spaces are ignored and the case (upper or lower) of characters after the 'AT' does not matter. The command line is terminated by <CR>, by 250 characters (not including the 'AT') or by a time-out (from successful auto-bauding on an 'AT') of 180 seconds.

All characters in the Hayes command, including the 'AT' and <CR> terminator are echoed (if E1 is set) by the CMX228 as they are sent by the DTE.

Receipt of a back space will cause the CMX228 to send a "back space, space, back space" sequence of characters to the DTE to allow the terminal to clear its screen of the last character. Also the last character received will be discarded unless the last characters received were the 'AT' used for auto-bauding, ie the 'AT' is never deleted.

The escape sequence '+++ ' (with Guard Time = 1s before and after the sequence) will cause the CMX228 to enter the command state from the data state and to return an 'OK' response. Sending an ATO command will be ignored, ie the CMX228 remains in the command state.

The following is a more detailed description of the Hayes commands listed above:

A (Answer)

Format: ATA<CR>

Causes the CMX228 to answer an incoming data call, by sending a CONNECT message to the network. If a CONNECT ACK is received the CMX228 enters the data state after returning a 'CONNECT XXX' result code to the DTE on the RS232 port (where the XXX is the speed in baud). If a RELEASE, RELEASE COMPLETE or DISCONNECT message is received a 'NO CARRIER' result code is returned. The command is not valid if there is no incoming call and it will return 'ERROR'.

D (Dial)

Format: ATD{DN}<CR>

Format: ATDT{DN}<CR>

Format: ATDP{DN}<CR>

{DN} is a directory number of up to 23 ASCII characters from 0..9, * and #. This form of the ATD command causes an outgoing SETUP message to be sent to the network with a Called Party Number Information Element which contains the digits included in the command. Any commands that follow this command are ignored.

If the CMX228 receives any character from the DTE after an ATD command, which causes a SETUP message to be sent to the network, and before the call is connected, the attempt to make a call is abandoned, ie a DISCONNECT message will be sent to the network and a 'NO CARRIER' result code returned.

Calls are established with the D command, irrespective of the state of the DTR pin. The result code response is either:

'CONNECT'	- call successful. The CMX228 will automatically enter the data state.
'NO CARRIER'	- call rejected by the remote user or the network
'NO DIALTONE'	- ISDN link down
'BUSY'	- remote user busy and other causes

Calls are cleared in the following way:

(i) The remote end or network clears the call by sending a DISCONNECT message or the ISDN line fails/is removed: 'NO CARRIER' is sent to DTE.

(ii) DTR is dropped (with a de-bounce period of 50ms) by DTE causing the CMX228 to send a DISCONNECT message to the network and enter the disconnect state, awaiting a RELEASE COMPLETE from the network. The CMX228 sends the 'OK' response when clearing of the ISDN call is complete ie RELEASE and RELEASE COMPLETE messages have been transmitted across the network, (dependant upon the state of &D command).

(iii) The DTE issues the escape sequence '+++ ' (with Guard Time = 1s before and after the sequence), receives an 'OK' response and then issues the Hang-up command (see section on H command below). The CMX228 sends the 'OK' response when clearing of the ISDN call is complete.

Incoming calls are indicated by a 'RING' result code. The call is automatically answered if S0 = 1 or more. If S0 = 0 an ATA command must be entered, then a CONNECT message is sent to the network.

E (Echo)

Format: ATEn<CR>

<u>Suffix n</u>	<u>Description</u>
0	Echo off
1 (default)	Echo on

This command tells the CMX228 whether or not to echo the characters received from the DTE when in command mode. When echo is on, all non control characters received from the DTE are echoed back to it.

H (Hang-up)

Format: ATH<CR>

Causes the CMX228 to clear the data call in progress. The command is not valid if there is no data call in progress but always returns an 'OK' result code. It is only valid in the command state when a data call is in operation, when it will send a DISCONNECT message to the network. Upon receipt of RELEASE, a RELEASE COMPLETE is transmitted to the network and 'OK' returned to the DTE.

I3 (Firmware Part Number)

Format: ATI3<CR>

Causes the CMX228 to return the part code and revision level to the DTE:

"CMX228: Vn.nn" where n.nn = version number

Q (Result Code Display)

Format: ATQn<CR>

<u>Suffix n</u>	<u>Description</u>
0 (default)	Result codes enabled
1	Result codes suppressed
2	Result codes are suppressed when an incoming call is received, otherwise enabled

V (Result Code Form)

Format: ATVn<CR>

<u>Suffix n</u>	<u>Description</u>
0	Result codes sent as numbers (see Data Call Result Codes below)
1 (default)	Result codes sent as words. This instructs the CMX228 to send the result codes as words or numbers to the DTE.

X (Result Code Set)

Format: ATXn<CR>

<u>Suffix n</u>	<u>Description</u>
0	0...4
1	0...4, 12, 14, 18, 28, 31
2	0...4, 12, 14, 18, 28, 31
3 (default)	0...4, 6, 7, 12, 14, 18, 28, 31
4	0...4, 6, 7, 12, 14, 18, 28, 31

This command causes the CMX228 to limit the data call result codes used to a given set. See Data Call Result Codes below for a list of codes and their meanings.

Data Call Result Codes

The data call result codes supported are:

<u>Numbers</u>	<u>Words</u>
0	'OK'
1	'CONNECT'
2	'RING'
3	'NO CARRIER'
4	'ERROR'
6	'NO DIALTONE'
7	'BUSY'
12	'CONNECT 9600'
14	'CONNECT 19200'
18	'CONNECT 57600'
28	'CONNECT 38400'
31	'CONNECT 115200'

&C (Carrier Detect)

Format: AT&Cn<CR>

Changes the operation of the RS232 DCD (Data Carrier Detect) signal.

<u>Suffix n</u>	<u>Description</u>
0	Ignore connection status, keep DCD high and LED3 pin low (ie ON).
1 (default)	DCD tracks the status of the data connection, raised when the call is connected, lowered when cleared. LED3 pin tracks the inverse status of the DCD pin (ie high when data connection is cleared).

&D (Data Terminal Ready)

Format: AT&Dn<CR>

Determines the CMX228 operation if DTR is lowered during a call.

<u>Suffix n</u>	<u>Description</u>
0	No action
2 (default)	B or D-channel data call is cleared and auto-answer is suspended until DTR is raised again.

If &D2 is set and DTR is low when an incoming call is received, the call is accepted and Ring Indication is sent to the DTE. If an incoming call has been accepted and &D2 is set when DTR is lowered, the call is cleared.

&F (Load Factory Profile)

Format: AT&F<CR>

Sets the following commands and registers to their default values. It does not change the %A !B, !C registers or the &Z command.

Commands: E Q V X &C &D &K

Registers: S0 S37 %B %D %E %L

Format: AT&F9<CR>

Sets all commands and registers to the default values and resets LED indicator and RS232 interface pins accordingly.

&K (Flow Control)

Format: AT&Kn<CR>

Indicates the method of flow control to be used between the CMX228 and the DTE when in the data state. There is no flow control when the CMX228 is in the command state.

<u>Suffix n</u>	<u>Description</u>
0	No flow control
3 (default)	Bi-directional RTS/CTS signals

Flow control is only active when in an active data call, ie not when dealing with Hayes commands.

Flow control is applied to the DTE in the following situations:

- (i) The remote end signals flow control (the mechanism is protocol dependent).
- (ii) Several buffers of data are held waiting transmission across ISDN.

Flow control is applied to the remote end (the mechanism is protocol dependent) if excessive data is held pending transmission to the DTE, so as to prevent local buffer overflow.

&V (View Active/Stored Profiles)

Format: AT&V<CR>

Causes the CMX228 to display the following command and register values for the stored profile:

Commands: E Q V X &C &D &K &Z

Registers: S0 S37 %A !C %E %B %D %L !B

&Z (Store Directory Number)

Format: AT&Z3={DN}<CR>

This command instructs the CMX228 to store a directory number. The stored directory number is then used by the X.25 call setup as the 'Calling NUA'.

A directory number consists of a string of characters from the set 0..9, ♦ and #. The '=' character can be omitted. Where a store number is entered, only the value 3 will give an 'OK' response. The contents of the &Z directory number are displayed by using the &V0 command. Up to 20 digits can be saved. The number must be in quotes. eg at&z3 = '12345'.

1.5.6.2 Hayes Register Set

In addition to the commands, there are a group of registers for which data is entered in the following format: AT{register}={value}<CR>. The following Hayes registers are supported:

S0	- Number of rings on which to auto-answer
S37	- Maximum rate adaption speed
%A2	- B/D-channel protocol
%B0	- X.25 receive window size
%B1	- X.25 transmit window size
%B2	- X.25 receive packet size
%B3	- X.25 transmit packet size
%B13	- X.25 NUI
%B18	- X.25 user data
%D0	- X.25 default receive window size
%D1	- X.25 default transmit window size
%D2	- X.25 default receive packet size
%D3	- X.25 default transmit packet size
%D9	- X.25 group number
%D10	- X.25 channel number
%E8	- V.120 MFO mode selection
%L3	- PAD forwarding character
%L4	- PAD idle timer
%L10	- PAD line folding
!B1	- LAPB T1 timer
!B2	- LAPB T4 timer
!B3	- LAPB N2 retry count
!B5	- X.25 LAPB active/passive
!C4	- B1-channel configuration
!C5	- B2-channel configuration
!C6	- Multiple Subscriber Numbering
!C7	- TEI selection
!C8	- ISDN Line Failure Detection enable/disable

The following is a more detailed description of the Hayes registers listed above:

S0 (Rings on Which to Auto-answer a Data Call)

<u>Range</u>	<u>Default</u>	<u>Description</u>
0 to 255	0	If set to 0 auto-answering will be disabled. Any other value will cause one 'RING' result code to be sent to the DTE after which the call is answered.

S37 (Maximum Rate Adaption Speed)

This forces the baud rate when handling incoming calls, to that defined by the S37 register contents, provided auto-answer is set. Once a call is terminated the baud rate remains that set by the S37 register.

<u>Value</u>	<u>Rate (baud)</u>
0 (default)	Same as last AT speed
9	9600
12	19200
13	38400
18	57600
31	115200

%A2 (CSD Protocol)

Selects the protocol to be used for the circuit switched data calls. Note that %A2 cannot be changed while a B or D-channel call is active.

<u>Value</u>	<u>Description</u>
2 (default)	V.120 Rate Adaption on B-channel.
3	Voice Calls.
4	X.25 Rate Adaption on B-channel.
5	X.25 packet calls on D-channel.
6	X.25 to a packet switched data network reached by a B-channel data call. This involves a two stage call set up. Firstly a circuit switched call must be established to the X.25 node, followed by a virtual call to an X.25 destination. The ATD command is used for both call requests.
15	PPP.
20	Transparent protocol.

1.5.6.2.1 X.25 Virtual Circuit Parameters

All %B registers can be read using the %Bn? command.

%B0 (X.25 Receive Window Size)

Defines the maximum number of X.25 packets that may be received before an acknowledgement is sent.

<u>Value</u>	<u>Description</u>
0 (default)	Use the default value appropriate to the type of call, without negotiation, see %D registers.
1 to 7	Negotiate the receive window size according to the value entered.

%B1 (X.25 Transmit Window Size)

Defines the maximum number of X.25 packets that may be transmitted before an acknowledgement is expected. Use of the default value is recommended.

<u>Value</u>	<u>Description</u>
0 (default)	Use the default value appropriate to the type of call, without negotiation, see %D registers.
1 to 7	Negotiate the transmit window size according to the value entered.

%B2 (X.25 Receive Packet Size)

Defines the maximum number of bytes that may be received in an X.25 packet.

<u>Value</u>	<u>Description</u>
0 (default)	Use the default value appropriate to the type of call, without negotiation, see %D registers.
7	Negotiate for a maximum 128 bytes per packet.
8	Negotiate for a maximum 256 bytes per packet.
9	Negotiate for a maximum 512 bytes per packet.
10	Negotiate for a maximum 1024 bytes per packet.

%B3 (X.25 Transmit Packet Size)

Defines the maximum number of bytes that may be transmitted in an X.25 packet.

<u>Value</u>	<u>Description</u>
0 (default)	Use the default value appropriate to the type of call, without negotiation, see %D registers.
7	Negotiate for a maximum 128 bytes per packet.
8	Negotiate for a maximum 256 bytes per packet.
9	Negotiate for a maximum 512 bytes per packet.
10	Negotiate for a maximum 1024 bytes per packet.

%B13 (Network User Identification String)

A maximum of 32 ASCII characters. The default value is an empty string. The Network User Identification (NUI) string is used to identify the terminal to the packet switched network if necessary. If there is at least one character present, the NUI is transmitted to the network when the call is established.

%B18 (User Data)

Up to 12 ASCII characters. Default is an empty string. The X.25 user data field which is sent when the X.25 call is established.

1.5.6.2.2 X.25 Parameters

All %D registers can be viewed using the %Dn? command.

%D0 (Default receive Window Size (Negotiated))

Defines the default maximum number of X.25 packets that may be received before an acknowledgement is sent, only in use if %B0=0.

<u>Range</u>	<u>Default</u>	<u>Description</u>
1 to 7	2	Default receive window size.

%D1 (Default Transmit Window Size (Negotiated))

Defines the default maximum number of X.25 packets that may be transmitted before an acknowledgement is expected, only in use if %B1=0.

<u>Range</u>	<u>Default</u>	<u>Description</u>
1 to 7	2	Default transmit window size.

%D2 (Default Receive Packet Size (Negotiated))

Defines the default maximum number of bytes that may be received in an X.25 packet, only in use if %B2=0.

<u>Value</u>	<u>Description</u>
7	Maximum 128 bytes per packet.
8 (default)	Maximum 256 bytes per packet.
9	Maximum 512 bytes per packet.
10	Maximum 1024 bytes per packet.

%D3 (Default Transmit Packet Size (Negotiated))

Defines the default maximum number of bytes that may be transmitted in an X.25 packet, only in use if %B3=0.

<u>Value</u>	<u>Description</u>
7	Maximum 128 bytes per packet.
8 (default)	Maximum 256 bytes per packet.

9	Maximum 512 bytes per packet.
10	Maximum 1024 bytes per packet.

%D9 (Group Number)

Defines the group number used in outgoing call setup messages.

<u>Range</u>	<u>Default</u>	<u>Description</u>
0 to 7	4	Group number.

%D10 (Channel Number)

Defines the channel number used in outgoing call setup messages.

<u>Range</u>	<u>Default</u>	<u>Description</u>
0 to 255	0	Channel number.

1.5.6.2.3 V.120 Parameters**%E8 (Multiple Frame Operation Mode Selection)**

In Multiple Frame Operation (MFO) mode, frames are acknowledged and retransmitted if errors occur.

<u>Value</u>	<u>Description</u>
0	MFO mode on.
1(default)	MFO mode off.

1.5.6.2.4 X.25 PAD Parameters

All %L registers can be viewed using the %Ln? command.

%L3 (Selection of Data Forwarding Characters)

This register is used to specify the characters which, when received from the DTE, will cause the current packet of data to be transmitted. If set to zero, the packet is not transmitted until either the idle timer (%L4) expires, or the packet becomes full (%B3). The values listed below may be added together to combine the character sets indicated. The characters are as described in the ASCII character set.

<u>Value</u>	<u>Description</u>
0 (default)	None.
1	A to Z, a to z and 0 to 9.
2	CR.
4	ESC, BEL, ENQ and ACK.
8	DEL, CAN and DC2.
16	ETX and EOT.
32	HT, LF, VT and FF.
64	NUL, SYN, ETB, EM, SUB, FS, GS, RS, and US.

%L4 (Idle Timer)

<u>Range</u>	<u>Default</u>	<u>Description</u>
0 to 40	0	Specifies the duration of the timer (in units of 1/20 second) that, when it expires, causes the contents of

the current packet to be forwarded. If set to zero, there is no timed forwarding.

%L10 (Line Folding)

<u>Range</u>	<u>Default</u>	<u>Description</u>
0 to 255	0	Specifies the line length required. When the specified number of characters have been sent to the DTE a carriage return and line feed are sent to ensure that lines do not exceed the required length. A value of zero disables line folding.

Note: If %L3 and %L4 are both 0, characters will be forwarded as they become available.

1.5.6.2.5 B Channel LAPB Parameters

All !B registers can be viewed using the !Bn? command.

!B1 (LAPB T1 Timer)

<u>Range</u>	<u>Default</u>	<u>Description</u>
1 to 255	3	Sets the value, in seconds, of the LAPB T1 timer.

!B2 (LAPB T3 Timer)

<u>Range</u>	<u>Default</u>	<u>Description</u>
1 to 255	15	Sets the value, in seconds, of the LAPB T3 timer.

!B3 (LAPB N2 Retry Count)

<u>Range</u>	<u>Default</u>	<u>Description</u>
1 to 255	4	Sets the number of times the LAPB protocol will retry sending before giving up and applying recovery procedures.

!B5 (Active/Passive)

<u>Value</u>	<u>Description</u>
0 (default)	X.25 is Active ie initiates link initialisation.
1	X.25 is Passive and waits for the network to initialise the link.

1.5.6.2.6 Basic Configuration Parameters

!C4 (B1 Channel Mapping)

Enables data calls to be made and accepted on the B1-channel. If !C5 is set to 0 the outgoing call SETUP message will contain a Channel Identification Information Element set to B1-channel only.

<u>Value</u>	<u>Description</u>
0	Incoming data calls on the B1-channel are rejected with 'channel not acceptable' as the cause.
4 (default)	Incoming data calls on the B1-channel are accepted provided no other data call is present.

!C5 (B2 Channel Mapping)

Enables data calls to be made and accepted on the B2-channel. If !C4 is set to 0 the outgoing call SETUP message will contain a Channel Identification Information Element set to B2-channel only.

<u>Value</u>	<u>Description</u>
0	Incoming data calls on the B2-channel are rejected with 'channel not acceptable' as the cause.
4 (default)	Incoming data calls on the B2-channel are accepted provided no other data call is present.

Note: If both !C4 and !C5 =0 no data calls will be made or received.

!C6 (MSN Directory Number)

Also refer to ISDN MSN (section 1.5.3.5).

If there is a number saved in this register upon receipt of an incoming data call, the CMX228 will check for the presence of a Called Party Number Information Element. If present it will compare the number with that saved in the !C6 register. If they match, the call will be accepted, ie a 'RING' indication (RI pin is raised, then lowered after 3s) is returned to the DTE. If the Called Party Number Information Element and saved MSN do not match, the call is ignored. The command is entered as follows:

AT!C6="nnnn"<CR> if no digits are present within the quotes, the MSN is cleared.
Up to 23 digits may be entered.

!C7 (TEI selection)

Selects the fixed or negotiated TEI used on the ISDN link. Note that the value of !C7 only takes effect when the ISDN interface goes from de-activated to activated.

<u>Value</u>	<u>Description</u>
0-63	Fixed TEI, 0 to 63.
64 (default)	Negotiated TEI.

!C8 (ISDN Line Failure Detection enable/disable)

Enables or disables Line Failure Detection. (Refer to section 1.5.3.3).

<u>Value</u>	<u>Description</u>
0	Line Failure Detection disabled.
1 (default)	Line Failure Detection enabled.

1.5.7 Data Operation

1.5.7.1 Incoming B-Channel Data Calls

All incoming data calls which have valid channel use and MSN are directed to the data port and cause 'RING' followed by the digits of the calling party number and the calling party subaddress (if received in the SETUP message) to be returned to the DTE. The Ring Indicator (RI) pin is also raised, then lowered after 3s. 'RING' text and the raising of RI for 3s is repeated every 6s until the call is cleared or answered, provided S0=0. If S0=1 then only one RING will appear at the DTE and the RI line will be raised only once, as a CONNECT message will be sent to the network.

1.5.7.2 Outgoing B-Channel Data Calls

Outgoing calls are requested specifying either B-channel unless channel mapping is enabled via !C4 and !C5 registers. The SETUP message is sent without High Layer Compatibility or Low Layer Compatibility and with the following Bearer Capability:

- CCITT coding standard
- Unrestricted digital
- Circuit mode
- 64k information transfer rate

If there is a saved MSN in !C6 register all outgoing call SETUP messages will contain the saved number in a Calling Party Number Information Element.

1.5.7.3 X.25 Data Calls on the D-Channel

When D-channel data is selected (via Hayes register %A2), B-channel data calls cannot be made. Any incoming B-channel data calls will be rejected with 'Busy'.

1.5.7.4 Connected Calls

Once a call is connected to the digital port, whether it was incoming or outgoing, the DCD pin is set high to indicate that the call is connected (providing &C0 command is not given). If the DCD pin is set high, the LED3 pin will be set low.

1.5.7.5 Call Clearing

The call is cleared either by the ATH command or by the ISDN network. When the call has been cleared, the DCD pin is set low and the LED3 pin is set high (providing the &C0 command is not given).

1.5.8 Application Programmer's Interface

Details of this will be supplied to customers under a Non-Disclosure Agreement.

The following Memory Map indicates the main code areas used on the CMX228:

Function	Start Hex Address	End Hex Address
Code Space	000 000	01F FFF
External RAM	020 000	03F FFF
API area	0C0 000	0EF FFF
AMD79C30 ISDN Interface Chip	0F0 000	0F0 0FF
PSB21525 HDLC Driver Chip	0F0 100	0F0 1FF
Reserved	0F0 200	0FF FFF

1.5.9 Hardware Description

1.5.9.1 LED Status Indicators (LED1 to LED9, and ILFI)

LED1 (HK1) is low when the POTS port is off-hook, high when on-hook.

LED2 (AA) indicates that register S0 has been set to 1 or more when low and set to 0 when high (RS232 Auto Answer indication).

LED3 (DCD) is low when a call is connected via the RS232 port (if &C0 is set to '1'), high when a call is not connected to this port.

LED4 (RTS) is low if RTS on the RS232 port is active and vice versa, indicating flow control (RS232 Ready To Send).

LED5 (RXD) is low if data is being sent to the DTE (RS232).

LED6 (TXD) is low if data is being received from the DTE (RS232).

LED7 (DTR) is low if the de-bounced DTR line on the RS232 port is active and vice versa.

LED8 (AR) is pulsed high and low until the ISDN line is activated, when it remains low constantly.

LED9 (CN1) is high when the POTS port is connected to the ISDN network, low when not connected.

ILFI is high when an ISDN Link Failure is Indicated, low when the link is operational.

The functions of the LED and ILFI indicators are set out in the table below:

Pin No.	Designation	POTS port	RS232 port
12	LED1	Off-Hook	~
13	LED2	~	Auto-Answer
14	LED3	~	Carrier Detect
15	LED4	~	Ready to Send
16	LED5	~	Receive Data
17	LED6	~	Transmit Data
18	LED7	~	Data Terminal Ready
19	LED8	ISDN Line Activated	ISDN Line Activated
21	LED9	Call Connected	~
54	ILFI	ISDN Line Failure Indicator	ISDN Line Failure Indicator

1.6 Application Notes

1.6.1 General

The CMX228 is intended for use as part of an ISDN chipset. The CML recommended hardware implementation contains the following elements (refer to Figure 3):

'S' bus interface via RJ45 socket.

RJ11 analogue telephone socket and analogue circuitry.

ISDN line transformer.

AMD79C30 S-interface controller.

Single asynchronous RS232 interface via 9-way or 25-way D-type connector.

64K bytes external RAM.

16K Non-volatile memory.

Ten processor controlled LED indicator signals.

HDLC drivers for the 2 ISDN B-channels, both channels can be used for data transfer.

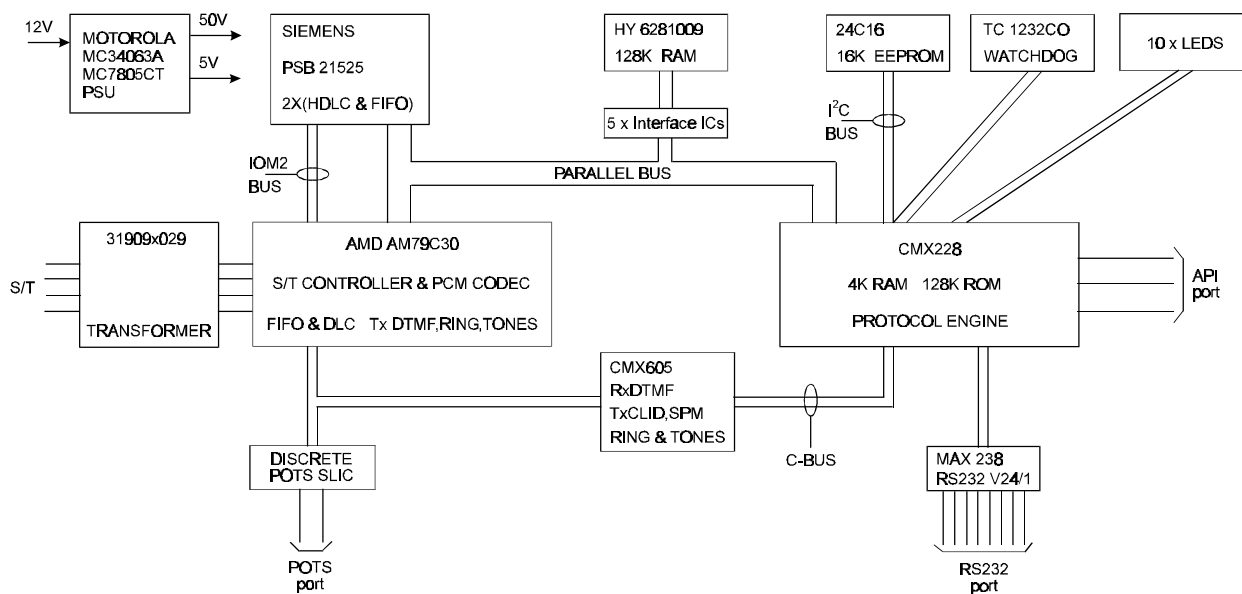

Figure 3 Application Block Diagram

1.6.2 Approvals

The firmware and finite state machine embedded in the CMX228 have been used in products which have gained ETSI CTR3 approval.

1.7 Performance Specification

1.7.1 Electrical Performance

1.7.1.1 Absolute Maximum Ratings

Exceeding these maximum ratings can result in damage to the device.

	Min.	Max.	Units
Supply ($AV_{DD} - AV_{SS}$), ($DV_{DD0} - DV_{SS0}$), ($DV_{DD1} - DV_{SS1}$)	-0.3	7.0	V
Voltage on any pin to AV_{SS} , DV_{SS0} or DV_{SS1}	-0.3	$V_{DD} + 0.3$	V
Current into or out of any V_{DD} or V_{SS} pin	-30	+100	mA
Current into or out of any other pin	-20	+10	mA

S1 Package (QFP)	Min.	Max.	Units
Total Allowable Power Dissipation at $T_{amb} = 25^{\circ}\text{C}$		1300	mW
... Derating		17	mW/ $^{\circ}\text{C}$
Storage Temperature	-55	+125	$^{\circ}\text{C}$
Operating Temperature	-40	+85	$^{\circ}\text{C}$

1.7.1.2 Operating Limits

Correct operation of the device outside these limits is not implied.

	Notes	Min.	Max.	Units
Supply: ($AV_{DD} - AV_{SS}$), ($DV_{DD0} - DV_{SS0}$), and ($DV_{DD1} - DV_{SS1}$)		2.7	5.5	V
Operating Temperature		-40	+85	$^{\circ}\text{C}$
32 MHz Xtal Frequency Tolerance		-100	+100	ppm

1.7.1.3 Operating Characteristics

Details in this section represent design target values and are not currently guaranteed.

For the following conditions unless otherwise specified:

Xtal Frequency = 32MHz \pm 100ppm, AV_{DD} = DV_{DD0} = DV_{DD1} = 3.0V to 5.0V, Tamb = - 40°C to +85°C.

	Notes	Min.	Typ.	Max.	Units
DC Parameters					
I _{DD} (total, operational)	1	–	25.0	45.0	mA
I _{DD} (total in HALT mode)	1	–	13.0	26.0	mA
I _{DD} (total in IDLE mode)	1	–	–	12.0	mA
Digital Interface					
Input logic "1" level		70%	–	–	V _{DD}
Input logic "0" level		–	–	30%	V _{DD}
Input leakage current (Vin = 0 to DV _{DD})		-10.0	–	+10.0	μA
Output logic "1" level (I _{OH} = -2mA)		V _{DD} -1.0	–	–	V
Output logic "0" level (I _{OL} = 2mA)		–	–	400	mV
Input or Output leakage current (Vout = V _{DD})		–	–	10	μA
Xtal/Clock Input					
'High' pulse width (t _{WXH})	2	10	–	125	ns
'Low' pulse width (t _{WXL})	2	10	–	125	ns
Risetime (t _{XR})	2	–	–	10	ns
Falltime (t _{XF})	2	–	–	10	ns
Period (t _{CYK})	2, 3	31.2468	–	31.2531	ns

- Notes:**
1. Not including any current drawn by external circuitry.
 2. Timing for an external input to the XTAL pin.
 3. A fundamental cut crystal is recommended.

Timing Diagrams (continued)

(3) Hold operation

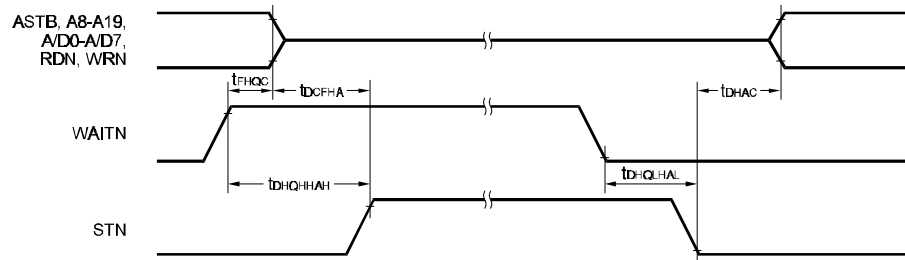
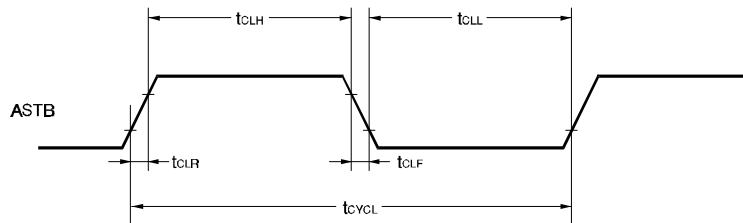
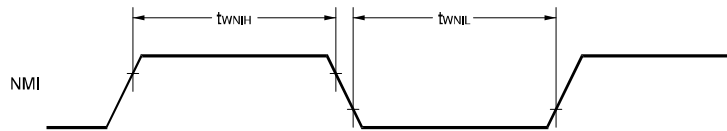

Figure 5 Bus Hold Timing

CLOCK OUTPUT TIMING



INTERRUPT INPUT TIMING



RESET INPUT TIMING

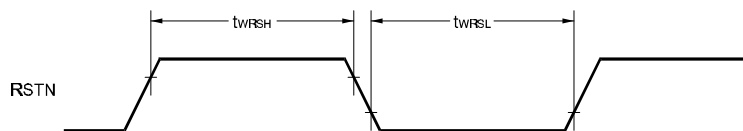

EXTERNAL CLOCK TIMING

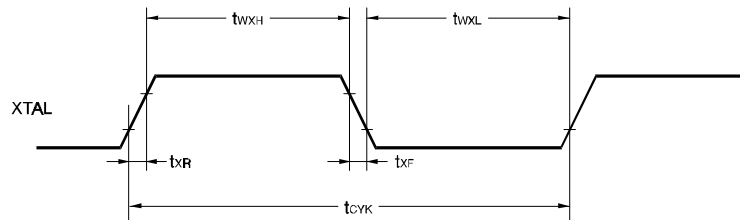

Figure 6 Miscellaneous Timing

AC Timing Parameters (continued)

For the following conditions unless otherwise specified:

Xtal Frequency = 32MHz, $V_{DD} = DV_{DD0} = DV_{DD1} = 3.0V$ to $5.0V$, $T_{amb} = -40^{\circ}C$ to $+85^{\circ}C$.

Read/Write operation (1/2)

Parameter	Symbol	Conditions	Min.	Max.	Units
Address setup time	t_{SAST}	$V_{DD} = +5.0V \pm 10\%$	$(0.5 + a) T - 15$	–	ns
ASTB high-level width	t_{WSTH}	$V_{DD} = +5.0 V \pm 10\%$	$(0.5 + a) T - 31$	–	ns
Address hold time to (ASTB↓)	t_{HSTLA}	$V_{DD} = +5.0 V \pm 10\%$	$(0.5 + a) T - 40$	–	ns
Address hold time (to RD↑)	t_{HRA}		0.5T - 24	–	ns
Delay from address to RD↓	t_{DAR}	$V_{DD} = +5.0V \pm 10\%$	0.5T - 34	–	ns
Address float time (to RD↓)	t_{FRA}		0.5T - 14	–	ns
Delay from address to data input	t_{DAID}	$V_{DD} = +5.0V \pm 10\%$	$(1 + a) T - 9$	–	ns
Delay from ASTB↓ to data input	t_{DSTID}	$V_{DD} = +5.0V \pm 10\%$	$(1 + a) T - 15$	–	ns
Delay from RD↓ to data input	t_{DRID}	$V_{DD} = +5.0 V \pm 10\%$	–	0	ns
Delay from ASTB↓ to RD↓	t_{DSTR}		–	$(2.5 + a + n) T - 37$	ns
Data hold time (to RD↑)	t_{HRID}		–	$(2.5 + a + n) T - 52$	ns
Delay from RD↑ to address active	t_{DRA}	$V_{DD} = +5.0 V \pm 10\%$ After program is read	–	$(2 + n) T - 40$	ns
		After program is read	–	$(2 + n) T - 60$	ns
		$V_{DD} = +5.0 V \pm 10\%$ After data is read	–	$(1.5 + n) T - 50$	ns
		After data is read	–	$(1.5 + n) T - 70$	ns
Delay from RD↑ to ASTB↑	t_{DRST}		0.5T - 9	–	ns
RD low-level width	t_{WRL}	$V_{DD} = 5.0 V \pm 10\%$	0	–	ns
Address hold time (to WR↑)	t_{HWA}		$(1.5 + n) T - 30$	–	ns
Delay from address to WR↓	t_{DAW}	$V_{DD} = +5.0V \pm 10\%$	$(1.5 + n) T - 40$	–	ns
Delay from ASTB↓ to data output	t_{DSTOD}	$V_{DD} = +5.0V \pm 10\%$	0.5T - 14	–	ns
Delay from WR↓ to data output	t_{DWOD}		$(1 + a) T - 5$	–	ns
Delay from ASTB↓ to WR↓	t_{DSTW}		$(1 + a) T - 15$	–	ns
			–	0.5T + 19	ns
			–	0.5T + 35	ns
			–	0.5T - 11	ns
			0.5T - 9	–	ns

Where: $T = t_{CYK}$ (system clock cycle time)
 $a = 1$ (during address wait), otherwise, 0
 $n =$ Number of wait states ($n = 2$)

Read/Write operation (2/2)

Parameter	Symbol	Conditions	Min.	Max.	Units
Data setup time (to WR↑)	t_{SODW}	$V_{DD} = +5.0 V \pm 10\%$	$(1.5 + n) T - 30$ $(1.5 + n) T - 40$	–	ns
Data hold time (to WR↑) ^{Note 1}	t_{HWOD}	$V_{DD} = +5.0V \pm 10\%$	0.5T - 5 0.5T - 25	–	ns
Delay from WR↑ to ASTB↑	t_{DWST}		0.5T - 12	–	ns
WR low-level width	t_{WWL}	$V_{DD} = +5.0V \pm 10\%$	$(1.5 + n) T - 30$ $(1.5 + n) T - 40$	–	ns

Note 1: Hold time includes the time during which V_{OH1} and V_{OL1} are held under the load conditions of $C_L = 50$ pF and $R_L = 4.7$ k Ω .

Bus Hold timing

Parameter	Symbol	Conditions	Min.	Max.	Units
Delay from WAITN↑ to float	t_{FHQC}		–	$(6 + a + n) T + 50$	ns
Delay from WAITN↑ to STN↑	$t_{DHQHHAH}$	$V_{DD} = +5.0 V \pm 10\%$	–	$(7 + a + n) T + 30$	ns
			–	$(7 + a + n) T + 40$	ns
Delay from float to STN↑	t_{DCFHA}		–	1T + 30	ns
Delay from WAITN↑ to STN↓	$t_{DHQLHAL}$	$V_{DD} = +5.0 V \pm 10\%$	–	2T + 40	ns
			–	2T + 60	ns
Delay from STN↓ to active	t_{DHAC}	$V_{DD} = +5.0 V \pm 10\%$	1T - 20 1T - 30	–	ns

Miscellaneous timing

Parameter	Symbol	Conditions	Min.	Max.	Units
ASTB cycle time	t_{CYCL}		nT	–	ns
ASTB low-level width	t_{CLL}	$V_{DD} = +5.0 V \pm 10\%$	0.5 t_{CYCL} - 10 0.5 t_{CYCL} - 20	–	ns
ASTB high-level width	t_{CLH}	$V_{DD} = +5.0 V \pm 10\%$	0.5 t_{CYCL} - 10 0.5 t_{CYCL} - 20	–	ns
ASTB rise time	t_{CLR}	$V_{DD} = +5.0 V \pm 10\%$	–	10 20	ns
ASTB fall time	t_{CLF}	$V_{DD} = +5.0 V \pm 10\%$	–	10 20	ns
NMI low-level width	t_{WNIL}		10	–	μ s
NMI high-level width	t_{WNIH}		10	–	μ s
RSTN low-level width	t_{WRSL}		10	–	μ s
RSTN high-level width	t_{WRSH}		10	–	μ s

Where: T = t_{CYK} (system clock cycle time)
a = 1 (during address wait), otherwise, 0.
n = Number of wait states (n = 2).

1.7.2 Packaging

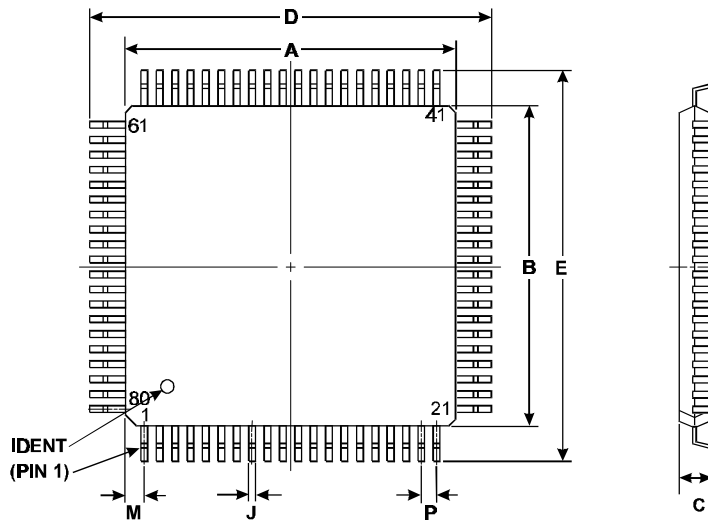

DIM.	MIN.	TYP.	MAX.
* A	0.543 (13.8)	0.560 (14.2)	
* B	0.543 (13.8)	0.560 (14.2)	
C		0.067 (1.70)	
D	0.669 (17.0)	0.685 (17.4)	
E	0.669 (17.0)	0.685 (17.4)	
H	0.002 (0.05)	0.008 (0.20)	
J	0.010 (0.26)	0.015 (0.38)	
L	0.023 (0.60)	0.040 (1.00)	
M		0.032 (0.825)	
P		0.026 (0.65)	
T	0.004 (0.10)	0.008 (0.20)	
X	0°		10°

NOTES : All dimensions in Inches (mm.)
Angles in degrees

*

Each lead centerline is located within 0.13 mm (0.005 inch) of its true position (T.P.) at maximum material condition

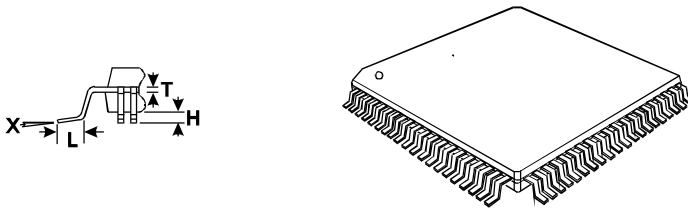

Figure 7 QFP Mechanical Outline: Order as part no. CMX228S1

Handling precautions: This product includes input protection, however, precautions should be taken to prevent device damage from electro-static discharge. CML does not assume any responsibility for the use of any circuitry described. No IPR or circuit patent licences are implied. CML reserves the right at any time without notice to change the said circuitry and this product specification. CML has a policy of testing every product shipped using calibrated test equipment to ensure compliance with this product specification. Specific testing of all circuit parameters is not necessarily performed.