

MMG-446040-S5 10 Watt 4.4 - 6.0 GHz GaN Power Amplifier

FEATURES

- Psat: +40dBm
- PAE: 40%
- Power Gain @ Psat: 27dB
- Small Signal Gain: 30dB
- QFN Package: 5.0 mm x 5.0 mm

Testing conditions: Pulsed RF signal with 1 ms pulse width and 20% duty cycle

DESCRIPTION

The MMG-446040-S5 is a high-performance gallium nitride (GaN) MMIC power amplifier. The MMG-446040-S5 provides >10W of saturated output power, 40% power-added efficiency, and 27 dB of large-signal gain between 4.4 GHz and 6.0 GHz. Both input and output are matched to 50 ohms. Ideal applications include wireless mesh networks, Point-to-point wireless data links, military wireless communications, telemetry, and avionics.

TYPICAL RF PERFORMANCE

$VDD1 = 15V, VDD2 = 15V, VDD3 = 28V, IDQ1 = 15mA, IDQ2 = 30mA, IDQ3 = 58mA, VG1 = -2.4V, VG2 = -2.41V, VG3 = -2.43V, Ta = 25\text{ }^{\circ}C, Z0 = 50\text{ohm}$

PARAMETER	UNITS	TYPICAL
Frequency Range	GHz	4.4 - 6.0
Gain	dB	30
Gain Flatness	+/-dB	0.8
Input Return Loss	dB	7.0
Output Return Loss	dB	15
Output Psat	dBm	40
PAE	%	> 37
EVM @ Pout of 32dBm or below	%	< 6
Operating Current Range	mA	See plot on page 2
Thermal Resistance	$^{\circ}C/W$	3.5

APPLICATIONS

- Wireless Mesh Networks
- Point-to-Point Microwave Data Links
- Military Wireless Communications
- Telemetry
- Avionics

FUNCTIONAL DIAGRAM

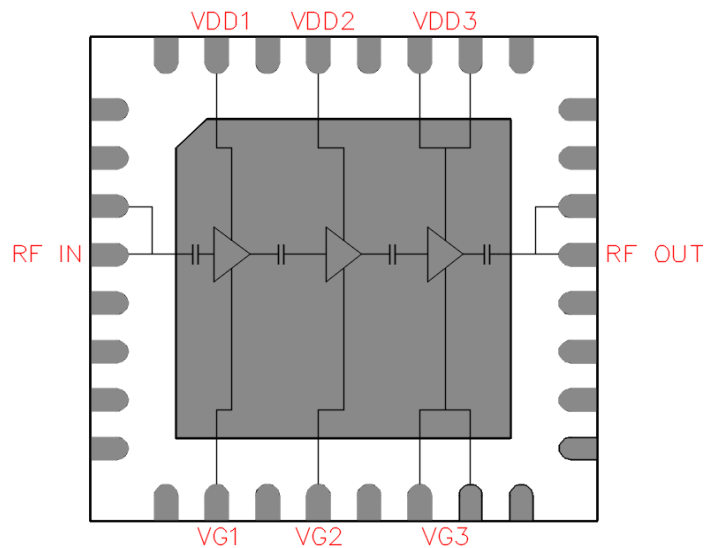

ABSOLUTE MAXIMUM RATINGS

$Ta = 25\text{ }^{\circ}C$

SYMBOL	PARAMETERS	UNITS	MAX
Vds	Drain to Source Voltage	V	50
Vgs	Gate to Source Voltage	V	10
Idd1	Drain Current of 1st Stage	mA	200
Idd2	Drain Current of 2nd Stage	mA	400
Idd3	Drain Current of 3rd Stage	mA	800
Ig1	Gate Current of 1st Stage	mA	0.8
Ig2	Gate Current of 2nd Stage	mA	1.5
Ig3	Gate Current of 3rd Stage	mA	3
Pdiss	DC Power Dissipation	W	50
Pin max	Max RF Input Power	dBm	+15
Tch	Channel Temperature	$^{\circ}C$	210
Tstg	Storage Temperature	$^{\circ}C$	-55 to 150

Exceeding any of these limits may cause permanent damage.

TYPICAL RF PERFORMANCE

Test conditions unless otherwise noted: $VDD1 = 15V$, $VDD2 = 15V$, $VDD3 = 28V$, $IDQ1 = 15mA$, $IDQ2 = 30mA$, $IDQ3 = 58mA$, $VG1 = -2.4V$, $VG2 = -2.41V$, $VG3 = -2.43V$, $T_a = 25^\circ C$, $Z_0 = 50\Omega$, Pulse Width = 1ms, Duty Cycle = 20%

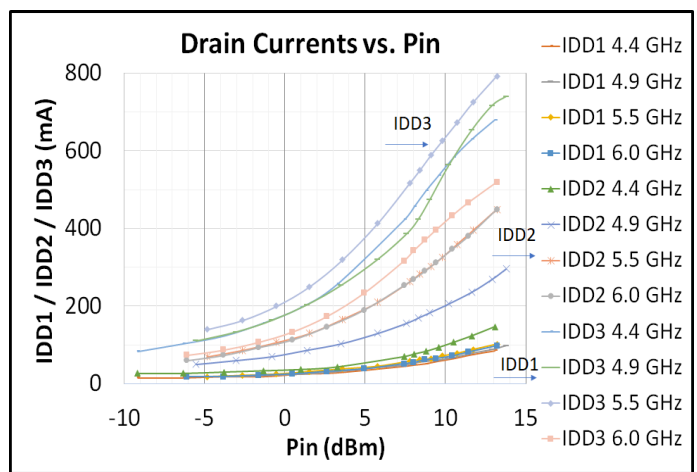
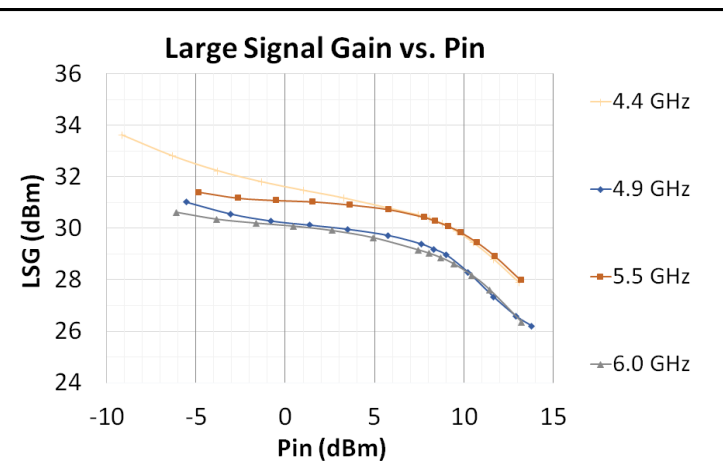
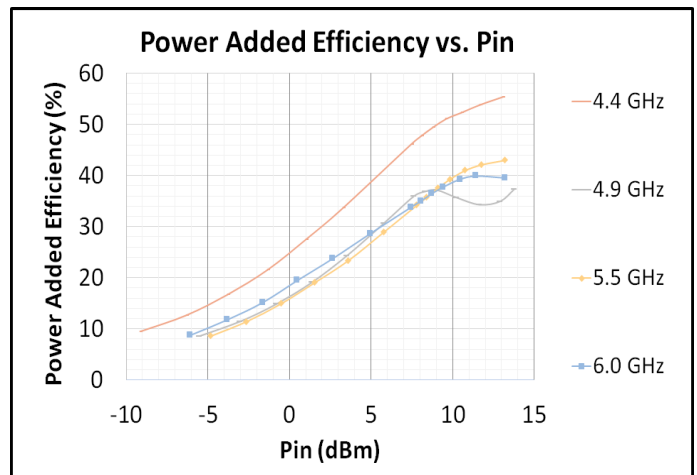
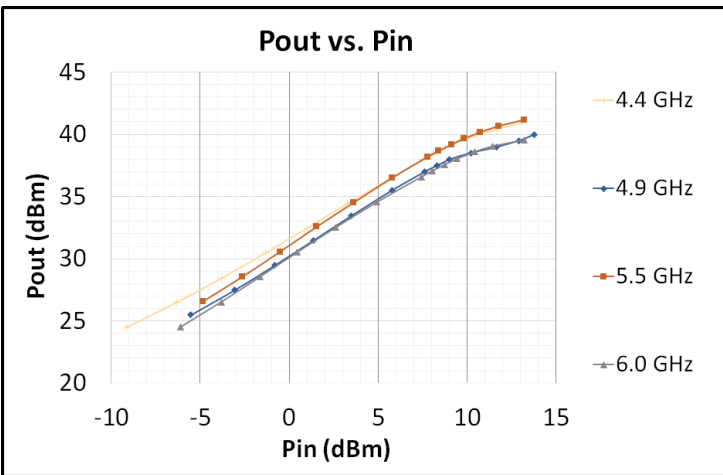
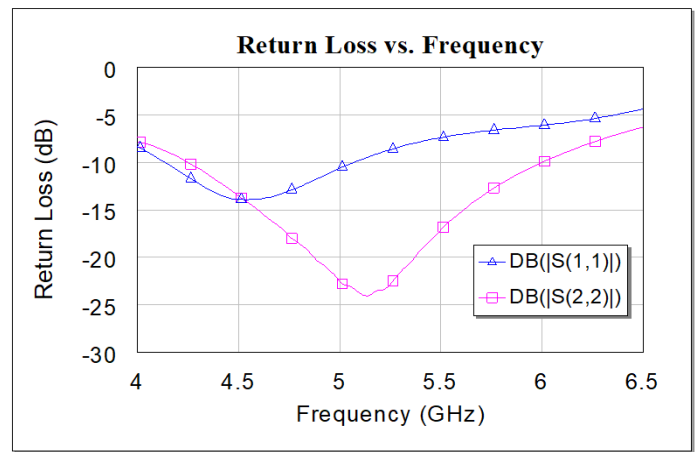
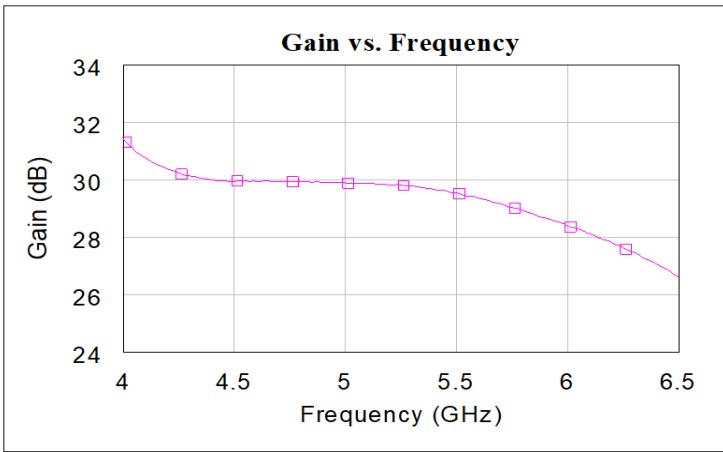

TYPICAL RF PERFORMANCE

Test conditions unless otherwise noted: $VDD1 = 15V$, $VDD2 = 15V$, $VDD3 = 28V$, $IDQ1 = 15mA$, $IDQ2 = 30mA$, $IDQ3 = 58mA$, $VG1 = -2.4V$, $VG2 = -2.41V$, $VG3 = -2.43V$, Wifi source: 802.11 64QAM3/4

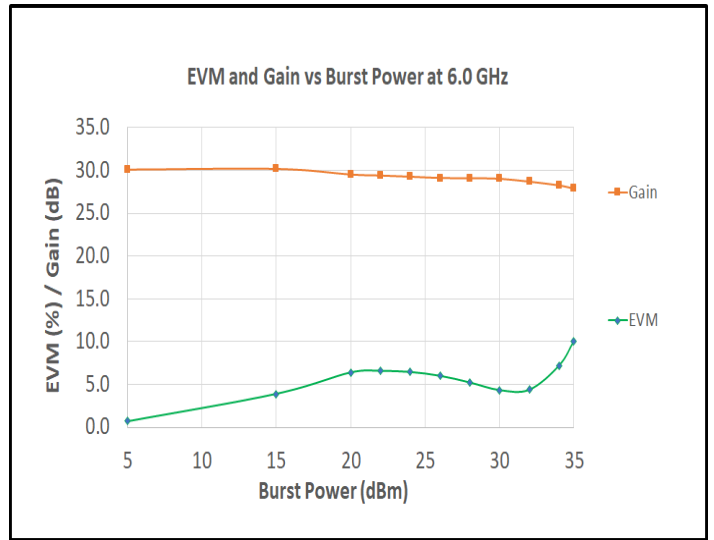
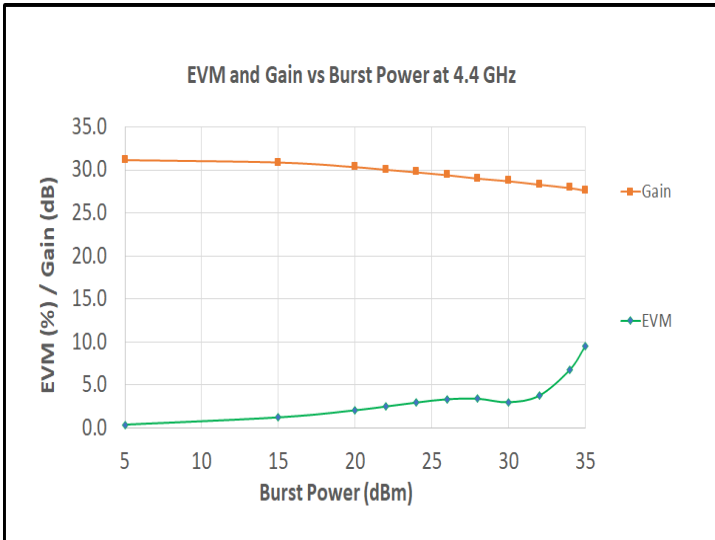

Evaluation Board

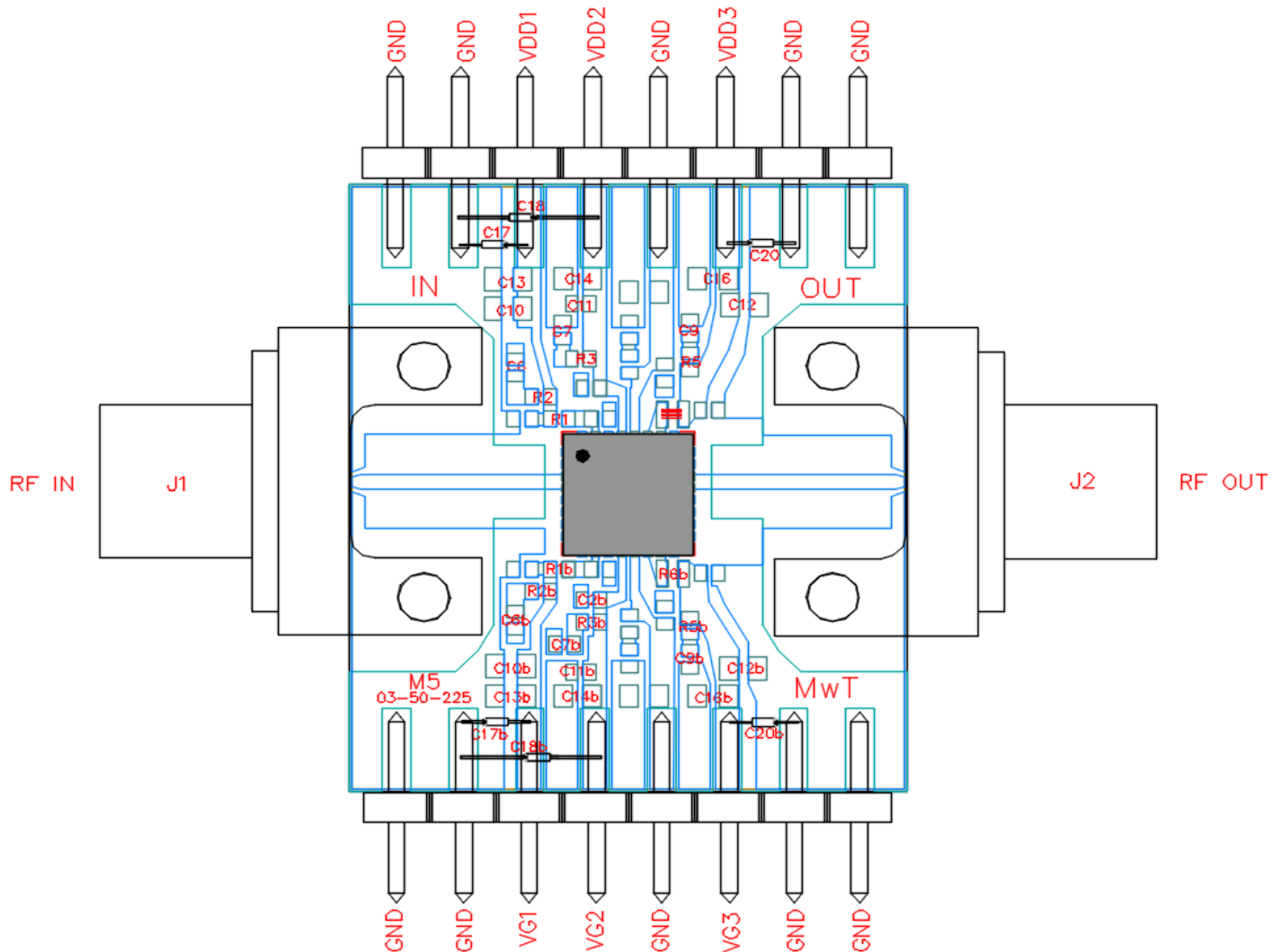

Bill of Materials

Reference	Value	Description	Manufacturer	Part Number
R1, R2, R3, R5, R1b, R2b, R3b, R5b, R6b	10 Ohm	RES, 5%, 0.2W, 0402	Various	
C6, C7, C7b, C9, C9b	0.5 pF	CAP, 20%, 50V, C0H, 0402	Various	
C10, C11, C12, C10b, C11b, C12b	0.1 uF	CAP, 10%, 50V, X8L, 0402	Various	
C13, C14, C16, C13b, C14b, C16b	1 uF	CAP, 10%, 35V, X5R, 0603	Various	
C17, C18, C20, C17b, C18b, C20b	1 uF	CAP, 10%, 50V, TANT, AXIAL	Various	M39003/01-2356
C2b	100 pF	CAP, 5%, 50V, NPO, 0402	Various	
C6b	1000 pF	CAP, 10%, 50V, X7R, 0402	Various	
J1, J2 (Connector) 03-50-225 (PCB)		SMA Female End Launch RO4350B, 0.254mm Thick	Southwest Microwave Various	292-06A-6

Schematic of Bias Circuit

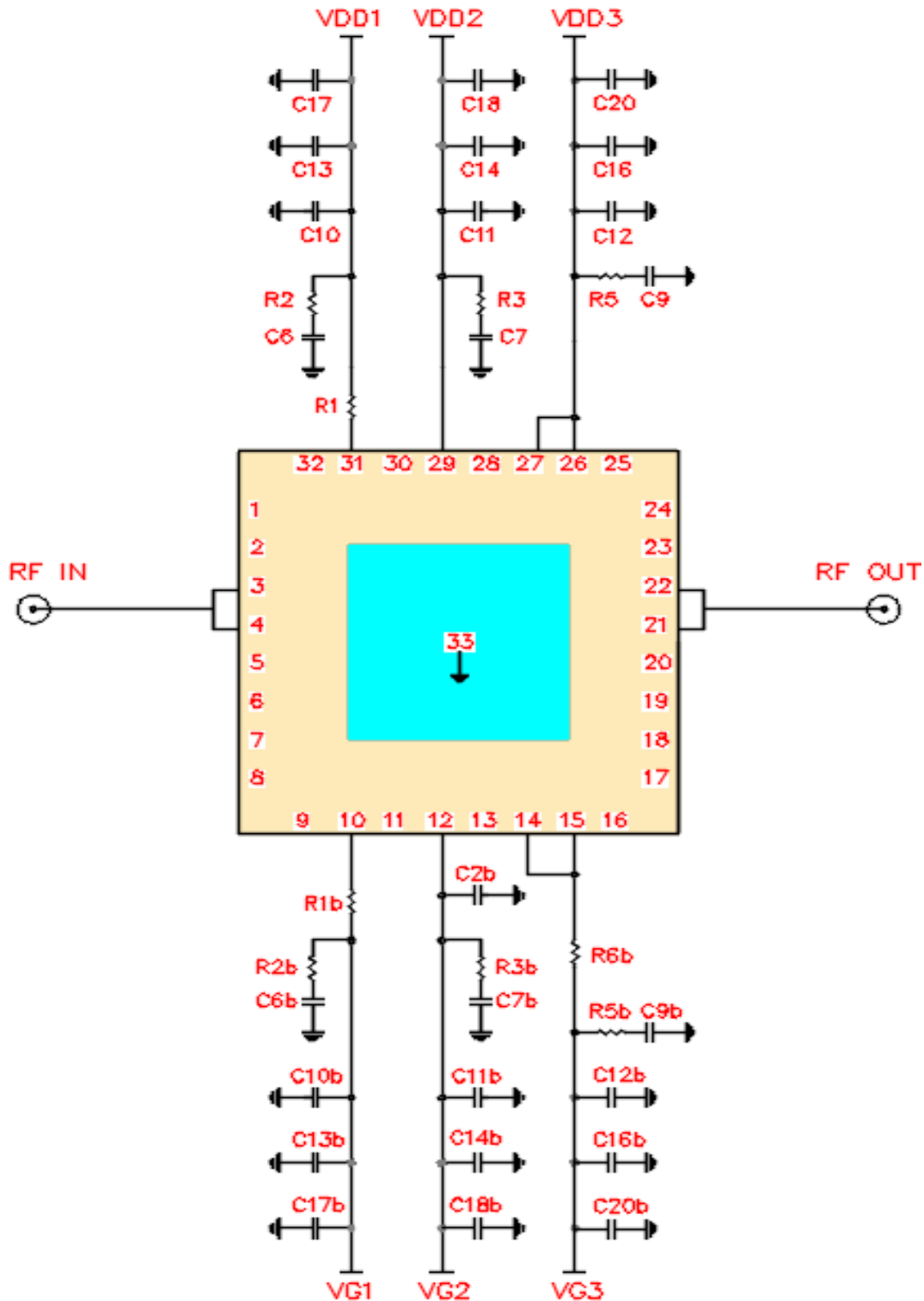

Pin Layout

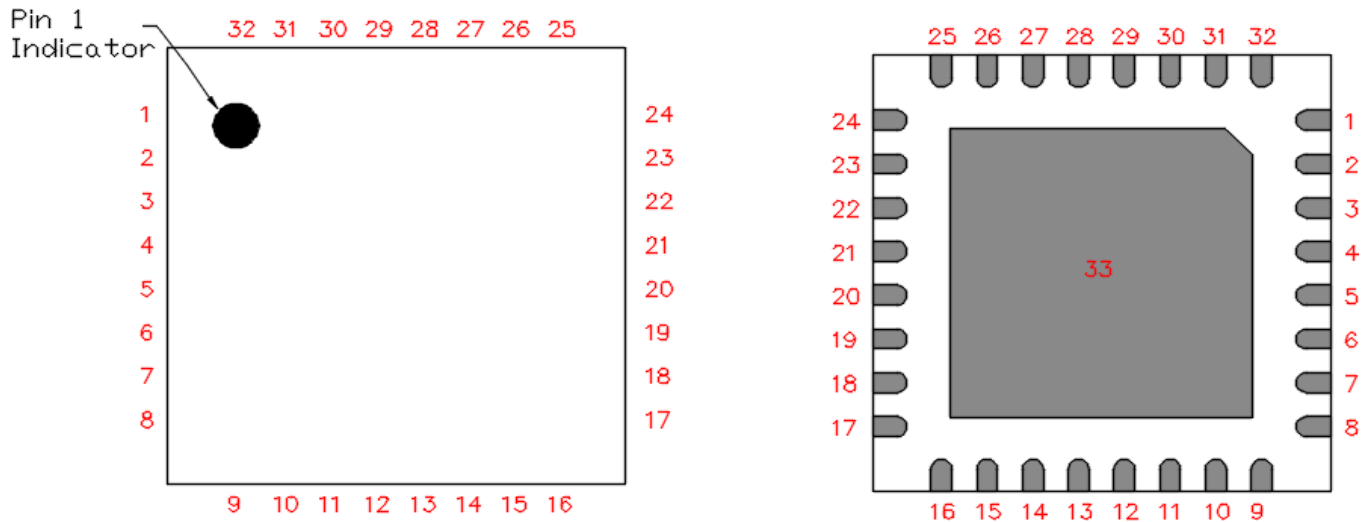

Pin Description

Pin Number	Symbol	Description
1, 2, 5-9, 11, 13, 16-20, 23-25, 28, 30, 32	NC	No connection inside of package.
3, 4	RF IN	RF input, 50 Ohms, DC blocked
10	VG1	Gate voltage of 1st stage. Biasing circuitry required
12	VG2	Gate voltage of 2nd stage. Biasing circuitry required
14, 15	VG3	Gate voltage of 3rd stage. Biasing circuitry required
21, 22	RF OUT	RF output, 50 Ohms, DC blocked
26, 27	VDD3	Drain voltage of 3rd stage. Biasing circuitry required
29	VDD2	Drain voltage of 2nd stage. Biasing circuitry required
31	VDD1	Drain voltage of 1st stage. Biasing circuitry required
33	GND	Center ground

Mechanical Information

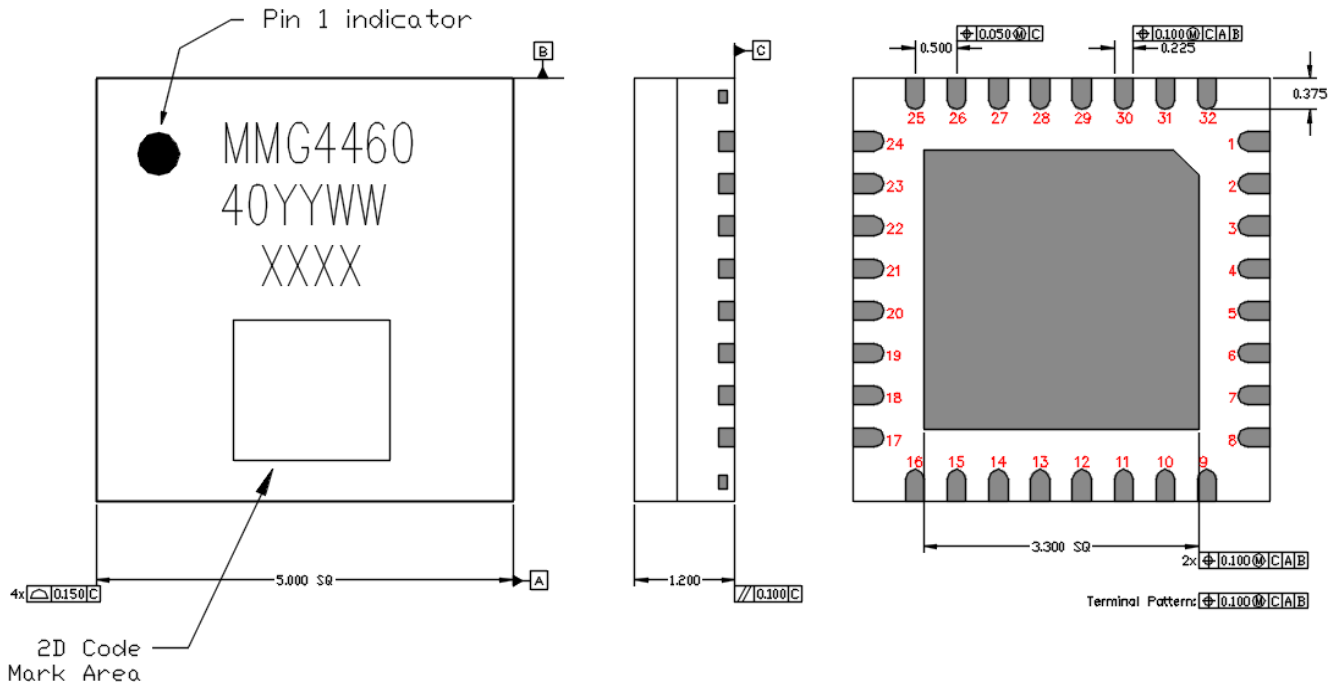

Notes:

1. All dimensions are in millimeters
2. Markings:
 - Line 1: MMG4460
 - Line 2: 40YYWW: YY for the last two digits of the year and WW for the work week
 - Line 3: XXXX (Lot code)
 - Line 4: 2D code for XXXX (Lot code) from line 3
3. Plating of the Package
 - Ni: 0.5um. MIN.
 - Pd: 0.02um. MIN.
 - Au: 0.05um. MAX.

MMG-446040-S5

10 Watt 4.4-6.0 GHz GaN Power Amplifier

Contact Information

For further information please contact your local CML sales representative.

Contact details can be found at www.cmlmicro.com