

## MMG-202543-S5 20 Watt 2.0 - 2.5 GHz GaN Power Amplifier

### FEATURES

- Psat: +44dBm
- PAE: >50%
- Power Gain @ Psat: 24dB
- Small Signal Gain: 27dB
- QNF Package: 5.0 mm x 5.0 mm

Testing conditions: Pulsed RF signal with 1ms pulse width and 20% duty cycle

### DESCRIPTION

The MMG-202543-S5 is a high-performance Gallium Nitride (GaN) MMIC power amplifier in a QFN package with high reliability. The MMG-202543-S5 provides >20W of saturated output power, >50% power-added efficiency, and 24 dB of large-signal gain between 2.0 GHz and 2.5 GHz. Both input and output are matched to 50 ohms. Ideal applications include wireless mesh networks, Point-to-point wireless data links, military wireless communications, telemetry, and avionics.

### TYPICAL RF PERFORMANCE

$VDD1 = 12V$ ,  $VDD2 = 28V$ ,  $IDQ1 = 34mA$ ,  $IDQ2 = 100mA$ ,  
 $VG1 = -2.45V$ ,  $VG2 = -2.45V$ ,  $Ta = 25\text{ }^{\circ}C$ ,  $Z0 = 50\text{ohm}$

PARAMETER	UNITS	TYPICAL
Frequency Range	GHz	2 - 2.5
Gain	dB	27
Gain Flatness	+/-dB	0.7
Input Return Loss	dB	7
Output Return Loss	dB	12
Output Psat (2.0 - 2.3 GHz)	dBm	45
Output Psat (2.4 - 2.5 GHz)	dBm	44
PAE (2.0 - 2.3 GHz)	%	48
PAE (2.4 - 2.5 GHz)	%	65
EVM @ Pout of 37dBm or below	%	< 5
Operating Current Range	mA	See plot on page 2
Thermal Resistance	$^{\circ}C/W$	4

### APPLICATIONS

- Wireless Mesh Networks
- Point-to-Point Microwave Data Links
- Military Wireless Communications
- Telemetry
- Avionics

### FUNCTIONAL DIAGRAM

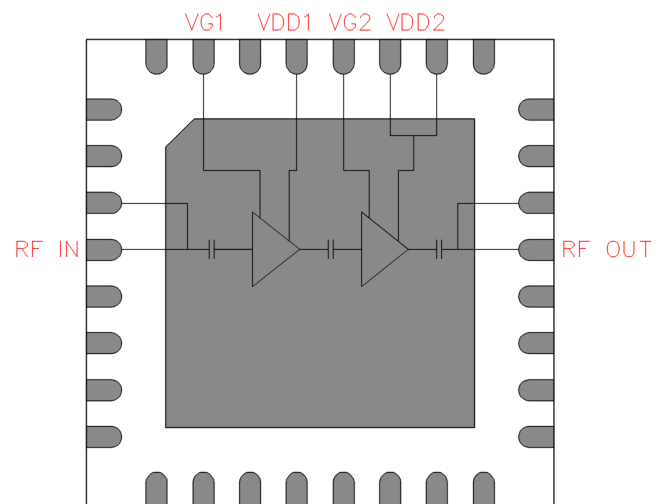

### ABSOLUTE MAXIMUM RATINGS

$Ta=25\text{ }^{\circ}C$

SYMBOL	PARAMETERS	UNITS	MAX
Vds	Drain to Source Voltage	V	50
Vgs	Gate to Source Voltage	V	10
Idd1	Drain Current of 1st Stage	mA	800
Idd2	Drain Current of 2nd Stage	mA	1500
Ig1	Gate Current of 1st Stage	mA	3
Ig2	Gate Current of 2nd Stage	mA	6
Pdiss	DC Power Dissipation	W	46
Pin max	Max RF Input Power	dBm	+22
Tch	Channel Temperature	$^{\circ}C$	210
Tstg	Storage Temperature	$^{\circ}C$	-55 to 150

Exceeding any of these limits may cause permanent damage.

### TYPICAL RF PERFORMANCE

Test conditions unless otherwise noted:  $VDD1 = 12V$ ,  $VDD2 = 28V$ ,  $VG1 = -2.45V$ ,  $VG2 = -2.45V$ ,  $IDQ1 = 34mA$ ,  $IDQ2 = 100mA$ ,  $T_a = 25^\circ C$ ,  $Z_0 = 50\Omega$

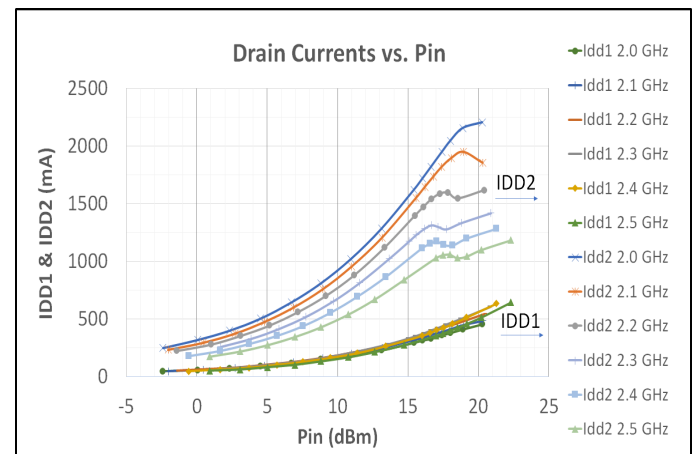
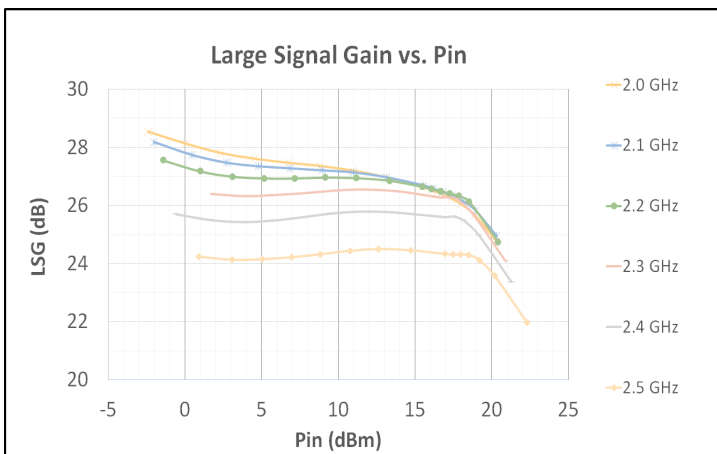
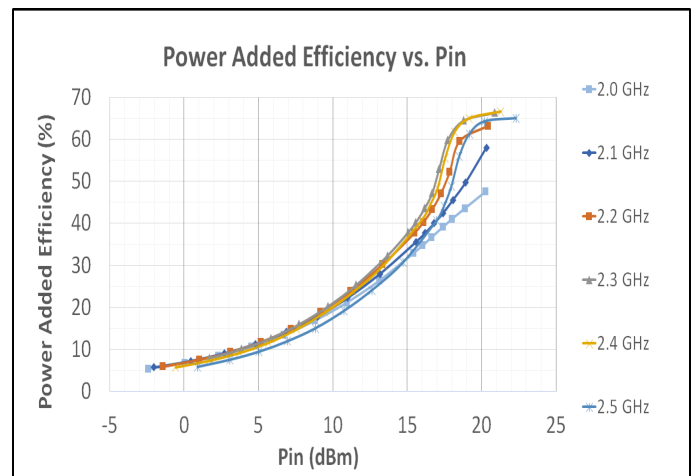
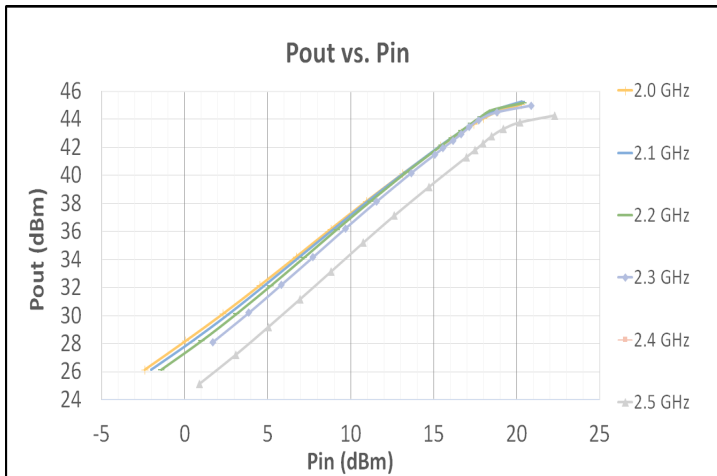
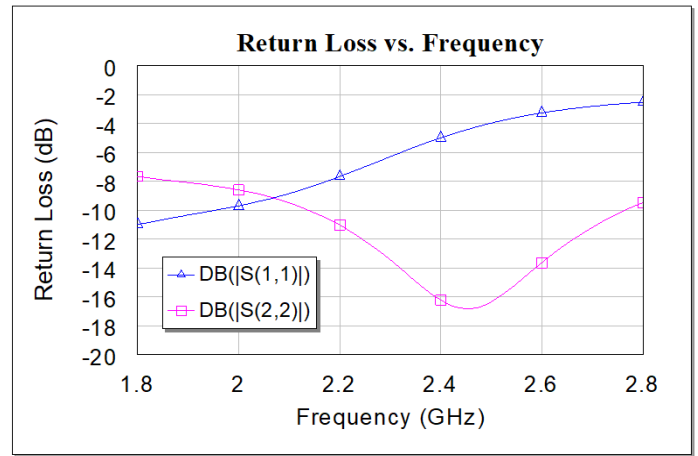
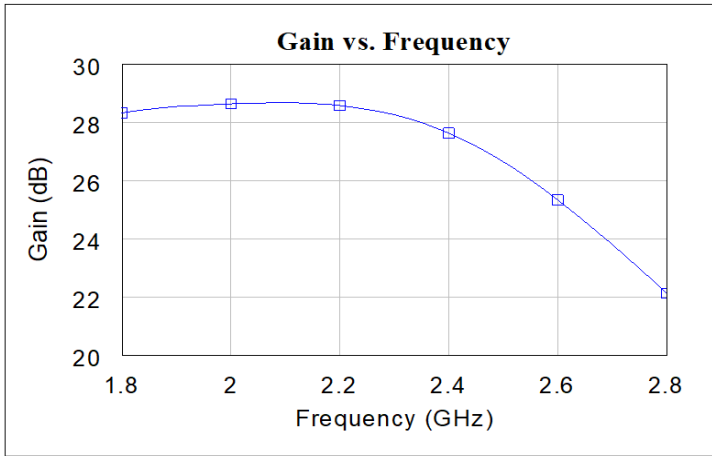

### TYPICAL RF PERFORMANCE

Test conditions unless otherwise noted:  $VDD1 = 12V$ ,  $VDD2 = 28V$ ,  $VG1 = -2.47V$ ,  $VG2 = -2.45V$ ,  $IDQ1 = 20mA$ ,  $IDQ2 = 100mA$ ,  $Ta = 25^{\circ}C$ ,  $Z0 = 50\Omega$ , Wifi source: 802.11 64QAM3/4

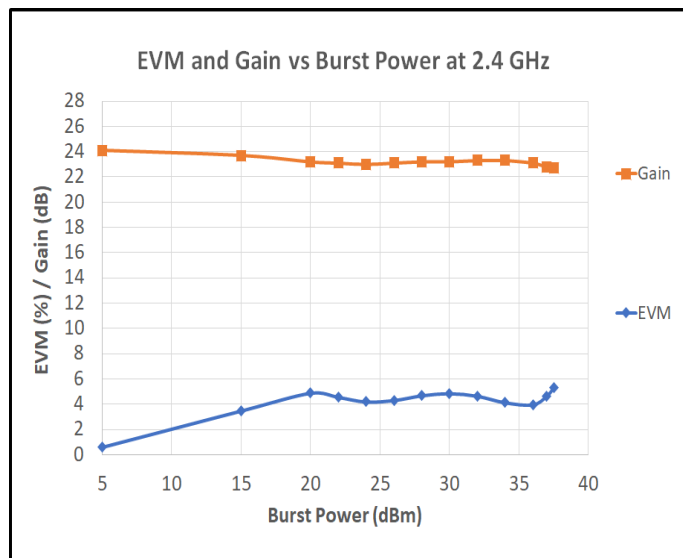
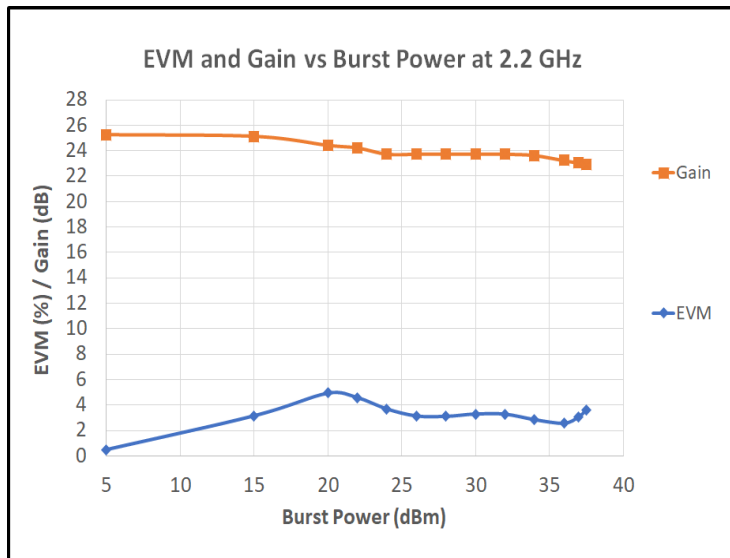

### Evaluation Board

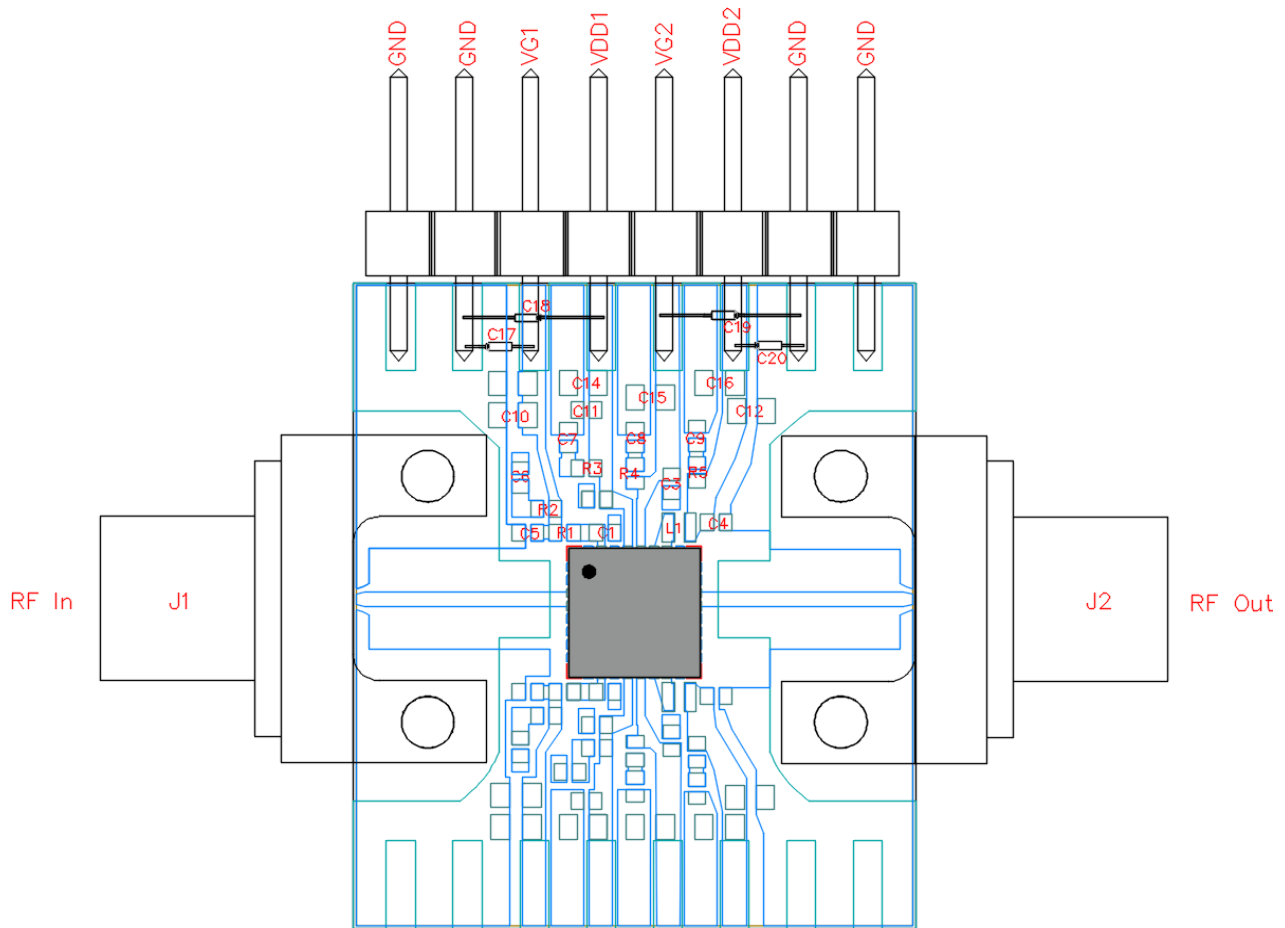

### Bill of Materials

Reference	Value	Description	Manufacturer	Part Number
C1, C3, C9	5 pF	CAP, 5%, 50V, NP0, 0402	Various	
C4	10 pF	CAP, 5%, 50V, NP0, 0402	Various	
C5, C8	100 pF	CAP, 5%, 50V, NPO, 0402	Various	
C6, C7, C15	1000 pF	CAP, 10%, 50V, X7R, 0402	Various	
C10, C14, C16	1 uF	CAP, 10%, 35V, X5R, 0603	Various	
C11, C12	0.1 uF	CAP, 10%, 50V, X8L, 0402	Various	
C17, C18, C19, C20	1 uF	CAP, 10%, 50V, TANT, AXIAL	Various	M39003/01-2356
R1	50 Ohm	RES, 5%, 0.0625W, 0402	Various	
R2, R3, R5	10 Ohm	RES, 5%, 0.2W, 0402	Various	
R4	0 Ω	RES, Jumper, 0402	Various	
L1	0.8 nH	IND, 5%, 0402, Ceramic Chip	Coilcraft	0402DC-N80XJRW
J1, J2 (Connector)		SMA Female End Launch	Southwest Microwave	292-06A-6
03-50-225 (PCB)		RO4350B, 0.254mm Thick	Various	

Schematic of Bias Circuit

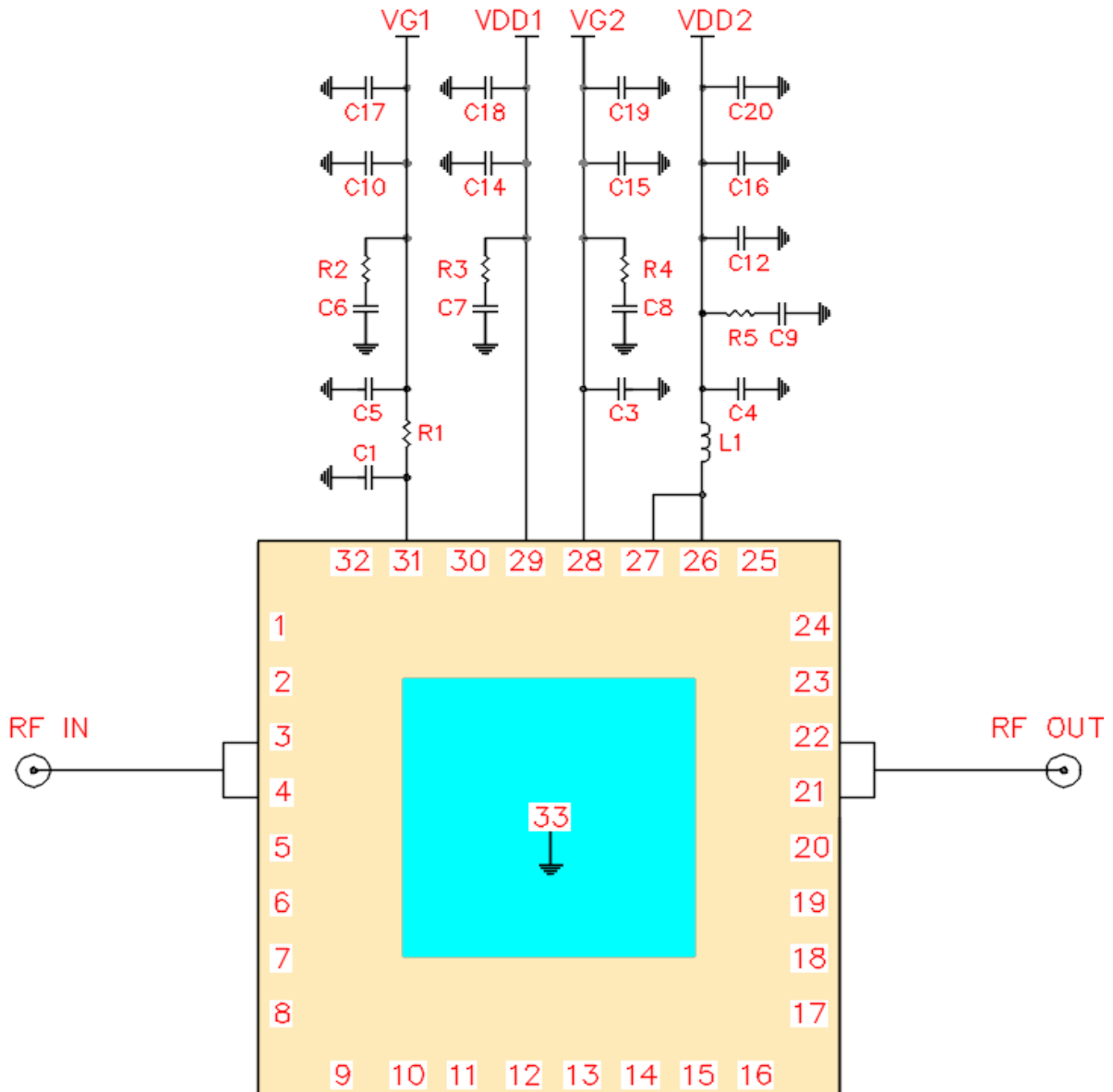

### Pin Layout

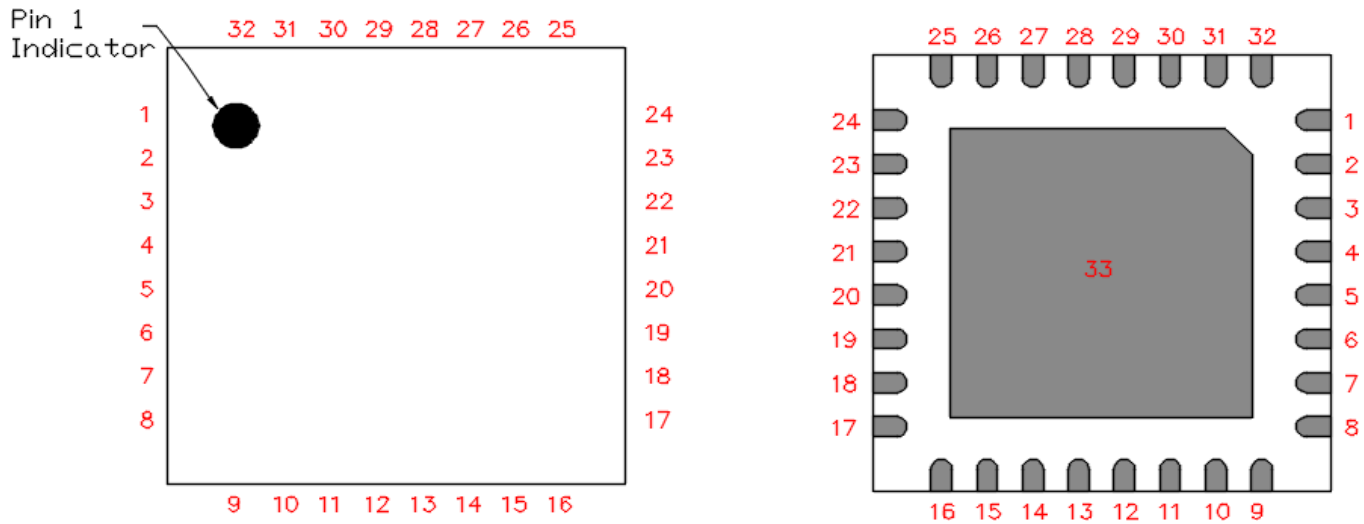

### Pin Description

Pin Number	Symbol	Description
1, 2, 5-20, 23-25, 32	NC	No connection inside of package
3, 4	RF IN	RF input, 50 Ohms, DC blocked
21, 22	RF OUT	RF output, 50 Ohms, DC blocked
26, 27	VDD2	Drain voltage of 2nd stage. Biasing circuitry required
28	VG2	Gate voltage of 2nd stage. Biasing circuitry required
29	VDD1	Drain voltage of 1st stage. Biasing circuitry required
31	VG1	Gate voltage of 1st stage. Biasing circuitry required
33	GND	Center ground

### Mechanical Information

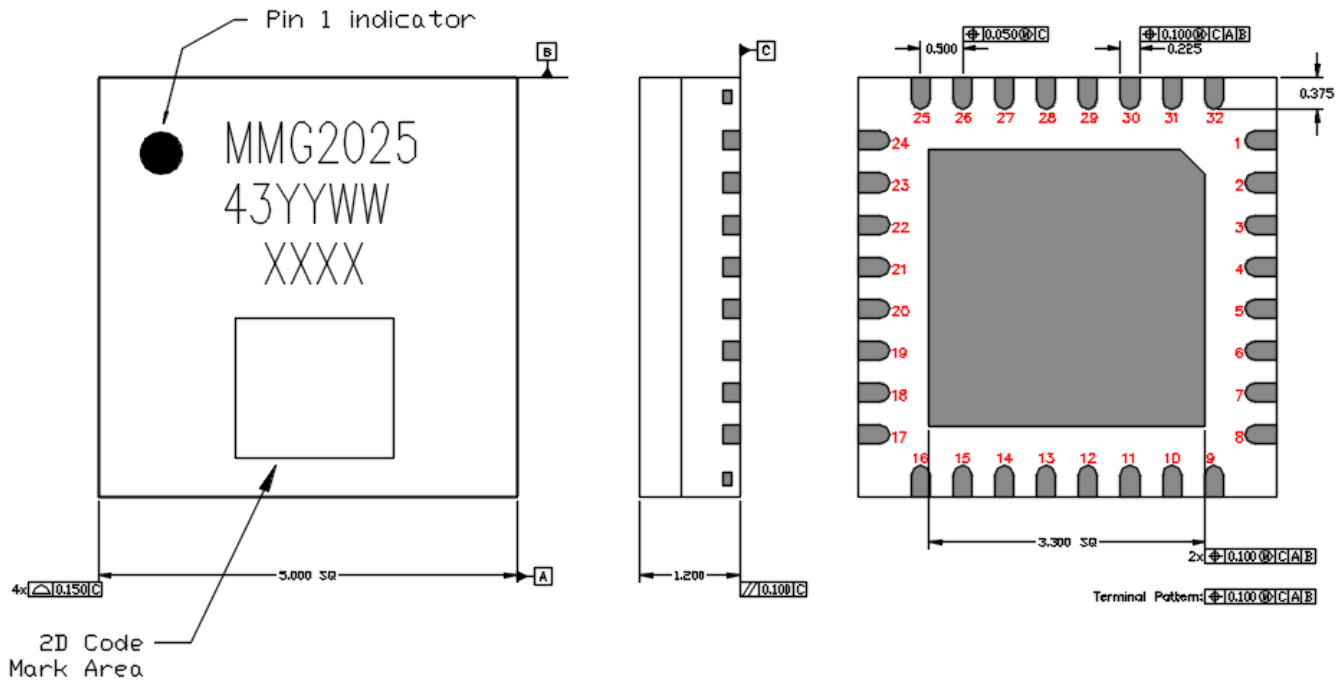

#### Notes:

1. All dimensions are in millimeters
2. Markings:
  - Line 1: MMG2025
  - Line 2: 43YYWW: YY for the last two digits of the year and WW for the work week
  - Line 3: XXXX (Lot code)
  - Line 4: 2D code for XXXX (Lot code) from line 3
3. Plating of the Package
  - Ni: 0.5um. MIN.
  - Pd: 0.02um. MIN.
  - Au: 0.05um. MAX.

## **Contact Information**

For further information please contact your local CML sales representative.

Contact details can be found at [www.cmlmicro.com](http://www.cmlmicro.com)