

1 Introduction

This document is intended as an aid to customers developing linear transmitters using the CMX998 integrated circuit^[1] by demonstrating a typical 'Cartesian Loop' transmitter solution using 'off-the-shelf' components. A test environment using the CMX998 Cartesian Feedback Loop (CFBL) IC and the CMX981 Advanced Digital Radio Baseband Processor IC^[2] is described. A Texas Instruments TMS320VC5510 DSK controls the CMX981. The CMX981 is used to generate $\pi/4$ -DQPSK modulation as is used in the TETRA standard (ref^[3]). It should be noted that this modulation is used as an example and the CMX998 is capable of being used with many other modulation schemes and international standards.

The test system described is used to linearize a power amplifier module from RF Micro Devices, the RF5110G^[4]. Tests are conducted at 800MHz and 400MHz. The design uses entirely RoHS compliant components.

Familiarity with the CMX998 and CMX981 datasheets is encouraged to increase the level of understanding of the information in this application note.

Table of Contents

1	Introduction	1
2	Hardware Configuration	3
2.1	Interconnections	3
2.2	CMX998 Input and Filter Amplifiers	4
2.3	CMX998 Error Amplifier	5
2.4	400MHz Tests	5
3	RF5110G Performance.....	6
3.1	Default Test PCB Configuration	6
3.2	Re-matched for 400MHz Operation	8
4	CMX998 and RF5110G	12
4.1	Operation at 800MHz / 850MHz.....	12
4.1.1	Results at 850MHz	12
4.1.2	Results at 800MHz	13
4.1.3	Operation with SMIQ	15
4.2	Operation at 400MHz	19
5	Conclusions.....	21
6	References.....	21

2 Hardware Configuration

The test setup uses the EV9980 CMX998 CFBL Evaluation board, the EV9810 CMX981 baseband processor evaluation board and a Texas Instruments TMS320VC5510 DSK. The diagram in Figure 1 indicates the connections made between the boards.

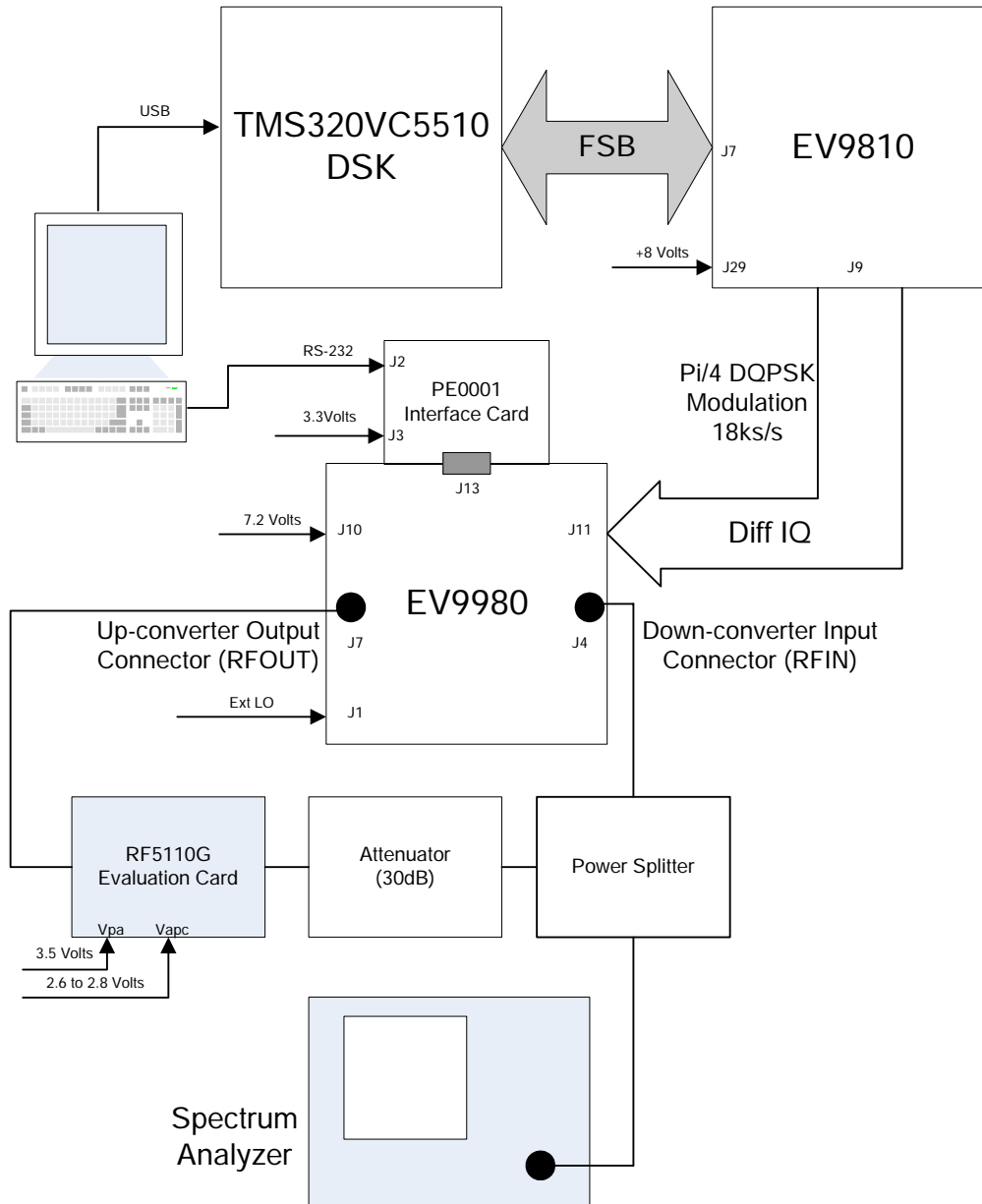

Figure 1 - Test Setup for RF5110G Evaluation with CMX998

2.1 Interconnections

A PC controls the system. The CMX998 is controlled via the PE0001 card and the CMX981 via the TMS320VC5510 DSK. The connections between the EV9810 and EV9980 are differential I and Q signals.

The power amplifiers on the EV9980 PCB are not used¹. The output from the CMX998 up-converter is connected to the RF5110G evaluation card (EV9980 RFOUT, connector J7). The amplified output is then attenuated and split to the spectrum analyzer (to measure results) and the CMX998 down-converter input (EV9980 RFIN, connector J4). The attenuation between the RF5110G output and the spectrum analyzer input was measured and corrected in all measurements (attenuator, splitter and cable losses). A signal generator provided a -10dBm local oscillator signal to the CMX998 (J1 EV9980 LO-In).

2.2 CMX998 Input and Filter Amplifiers

The input amplifiers on the CMX998 were configured as Figure 2, to allow the EV9980 to interface directly to the EV9810. (This arrangement is different from that used and shown in the EV9980 Datasheet– this scheme gives a better dc level based on BVREF).

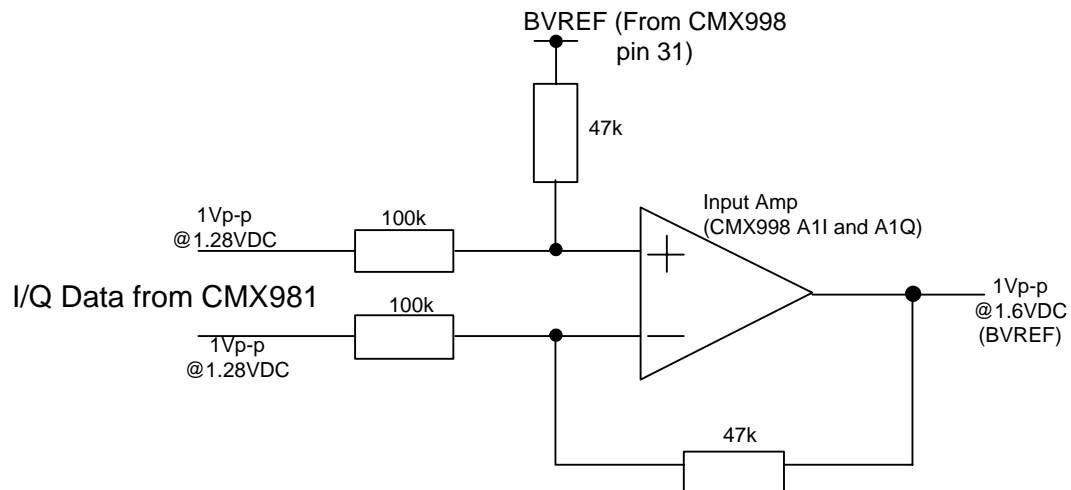

Figure 2 - CMX998 Input Amplifier Configuration

The CMX998 filter amplifiers have been configured with a low pass Sallen-Key topology that has a 3dB bandwidth of ~50kHz (this is the standard configuration fitted to EV9980 cards).

¹ C27=1nF, C30=1nF, C35=1nF, C54=1nF, C55=1nF, R29=0R

2.3 CMX998 Error Amplifier

The error amplifier configuration used in the tests is the standard EV9980 setup and is shown in Figure 3. The 1st Pole is at ~16kHz, the 2nd Pole is at ~32kHz and the Zero is at ~320kHz.

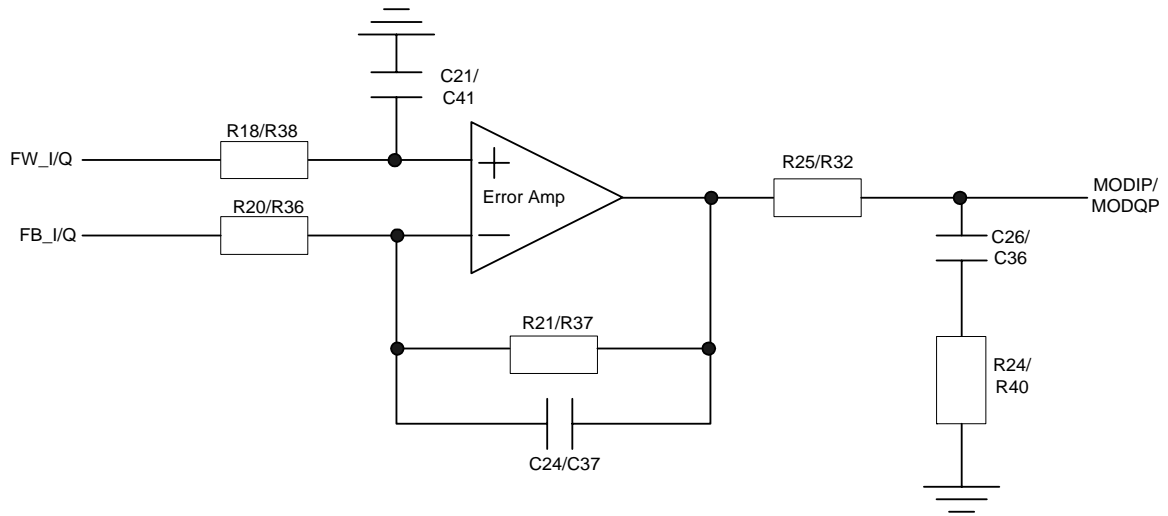

Figure 3 – Error Amplifier Configuration

2.4 400MHz Tests

For the 400MHz tests, the harmonic filter on the EV9980, which is normally in the feedback path from the coupler, was moved to the RFIN input path with the following changes:

- R33 = 8.2pF (Capacitor)
- R29 = 18nH (Inductor)
- R34 = 8.2pF (Capacitor)

3 RF5110G Performance

The following section details performance of the RF5110G measured 'stand alone' (i.e. driven from test equipment not the CMX998).

In all tests in this document the RF5110G power supply was +3.5 V.

3.1 Default Test PCB Configuration

The following plots show measured performance of the un-modified RF5110G evaluation card. It will be noted in Figure 4 that the characteristic is not very linear even before the onset of gain compression. The circuit has good gain at lower frequencies as well as the design frequency (850-900MHz) however when the input level is raised it is clear that the output at lower frequencies rapidly goes into compression indicating the device needs to be re-matched for UHF operation.

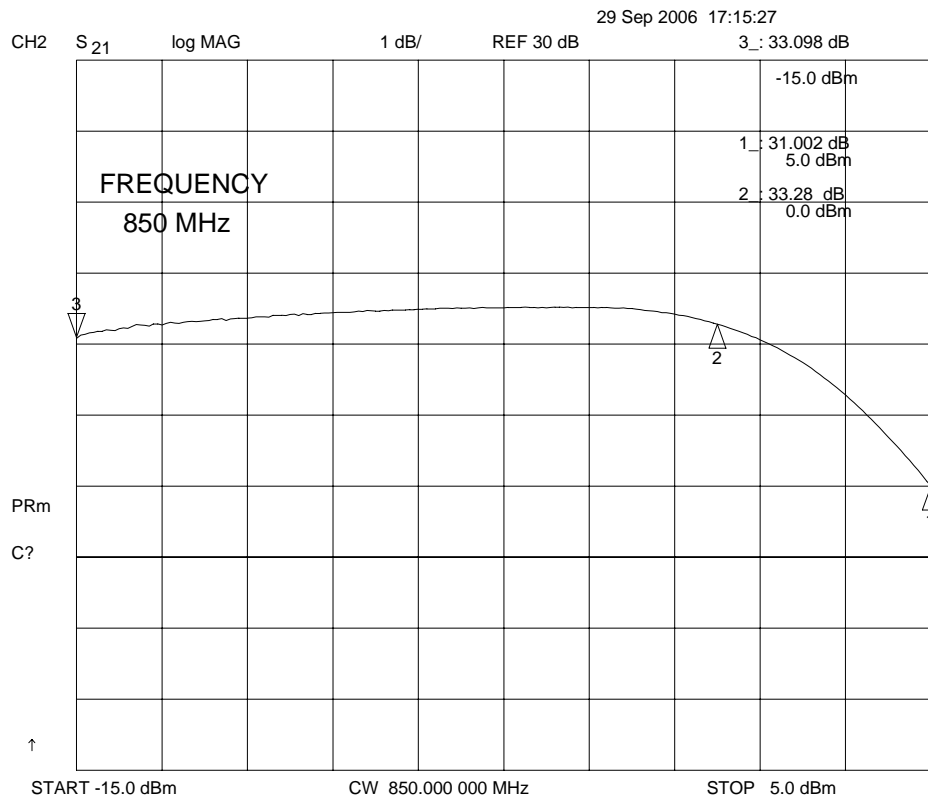

Figure 4 - Gain Compression Characteristic of RF5110G

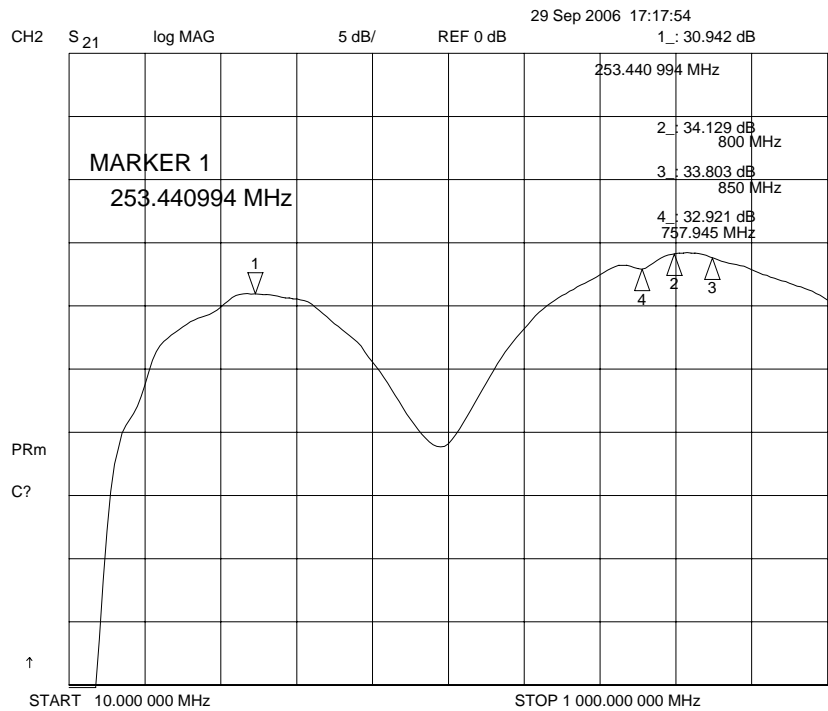

Figure 5 - Gain vs Frequency response of RF5110G Evaluation Card, input power -15dBm

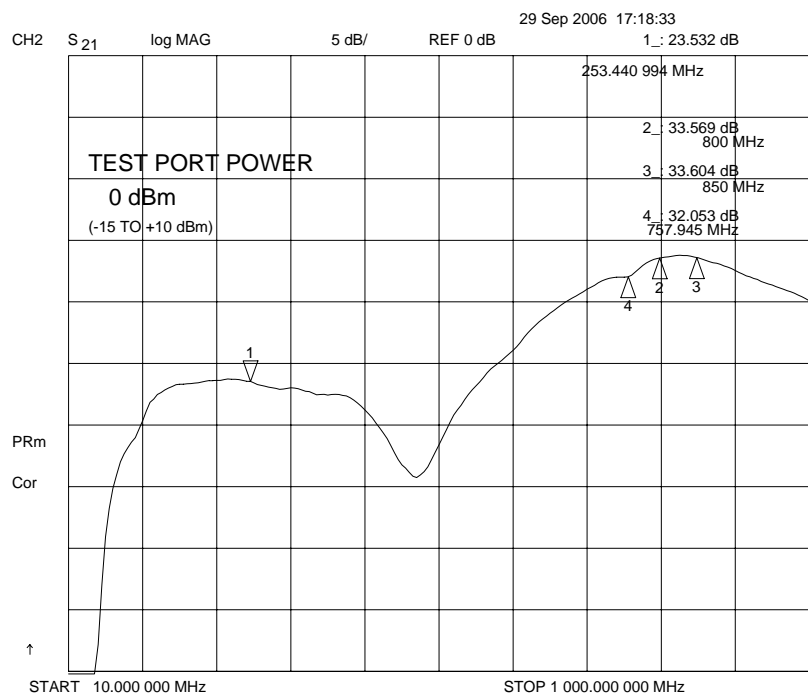

Figure 6 - Gain vs Frequency response of RF5110G Evaluation Card, input power 0dBm (note gain compression at lower frequencies)

The linearity of the RF5110G can be adjusted depending on the V_{apc} voltage. It was noticed that third order products could be optimized at V_{apc}=2.6V to 2.7V. However this results in higher levels of high order products. As a result it was concluded that V_{apc}=2.8V is about the optimum control voltage.

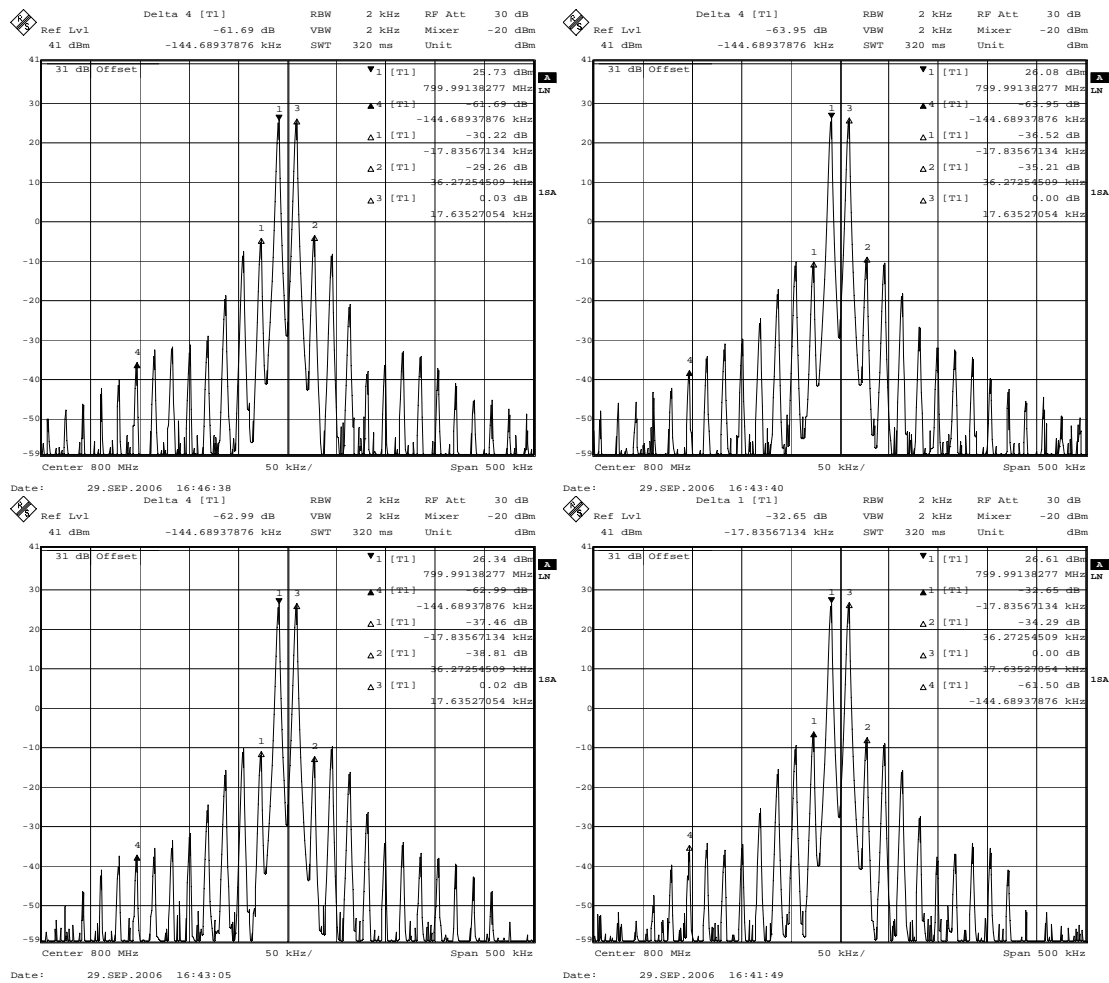

Figure 7 – PA Linearity with two-tone input for V_{apc}=2.5V (top left), 2.6V (top right), 2.7V (bottom left) and 2.8V (bottom right)

3.2 Re-matched for 400MHz Operation

The RF5110G matching was altered to optimize the performance for 400MHz, changes to the output match are shown in Figure 10. Other changes to decoupling recommended in the device datasheet^[4] were also implemented.

It was found that at 400MHz the device has rather high gain but the compression point is somewhat less than what was achieved at 800/900 MHz. This can be seen in Figure 9. The saturated output was around +34dBm. Although it may be possible to achieve slightly more output power this was felt to be sufficient for the present tests of a 1W (mean) transmitter.

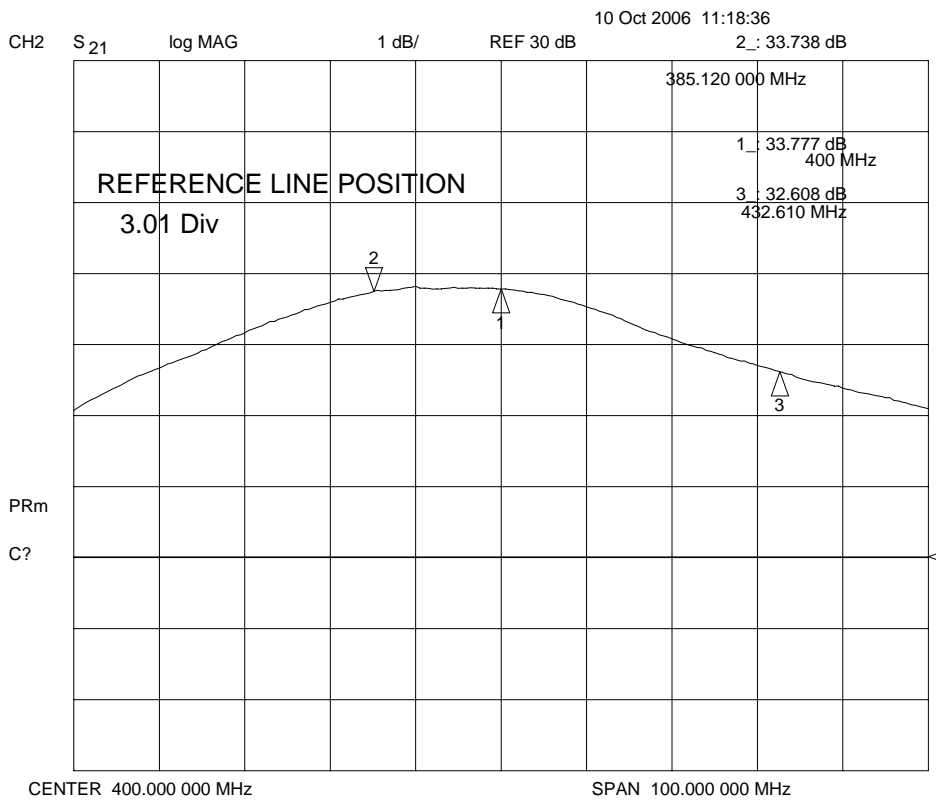
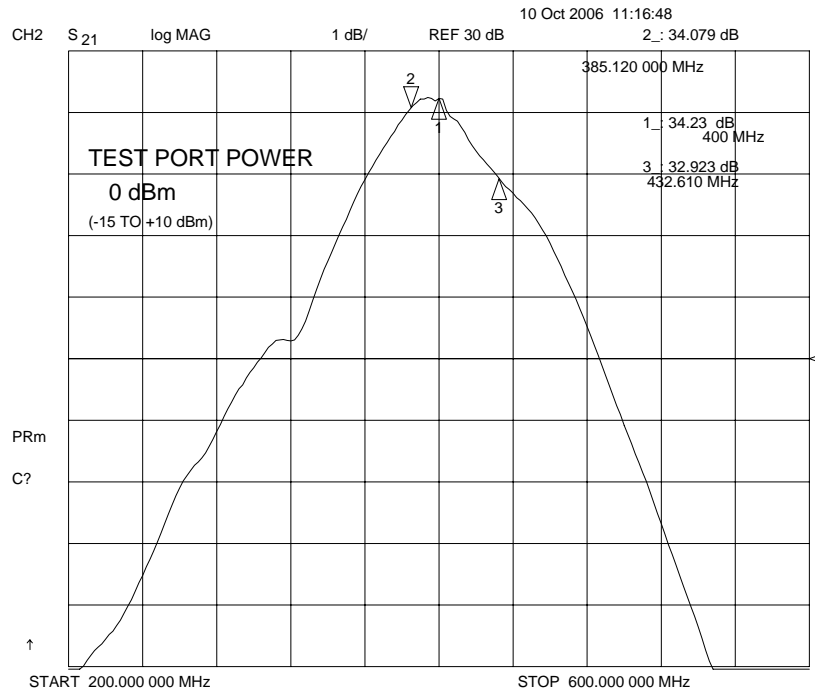

Figure 8 – Two plots of the response of RF5110G re-matched for 400MHz operation. The lower plot input power is +1dBm.

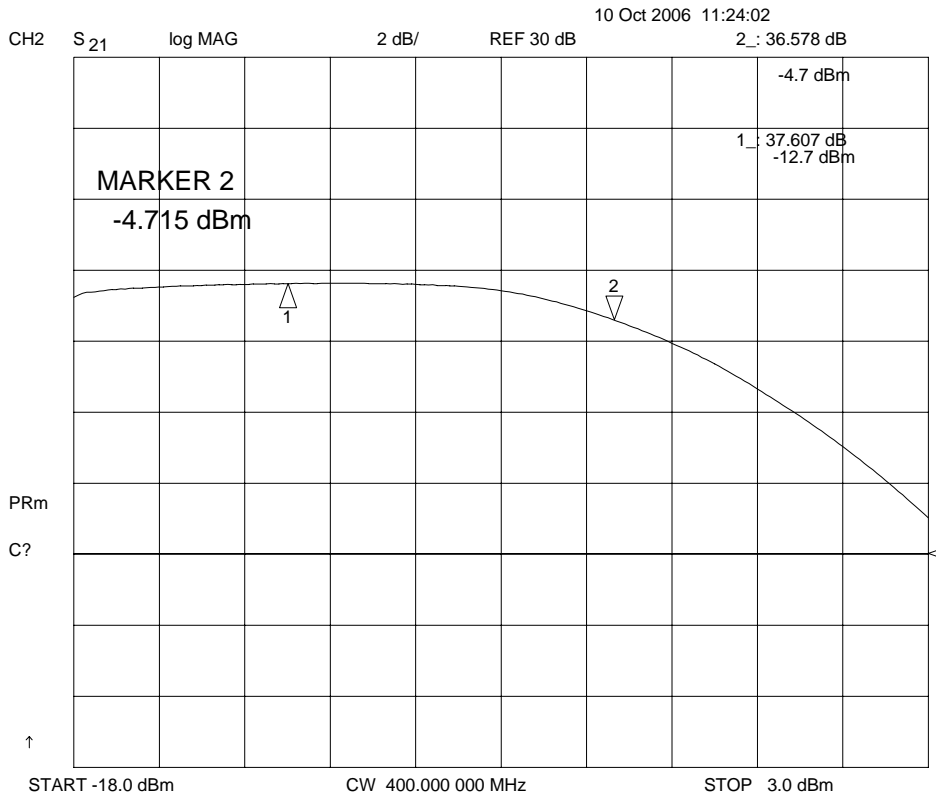

Figure 9 - Gain compression response of RF5110G at 400MHz

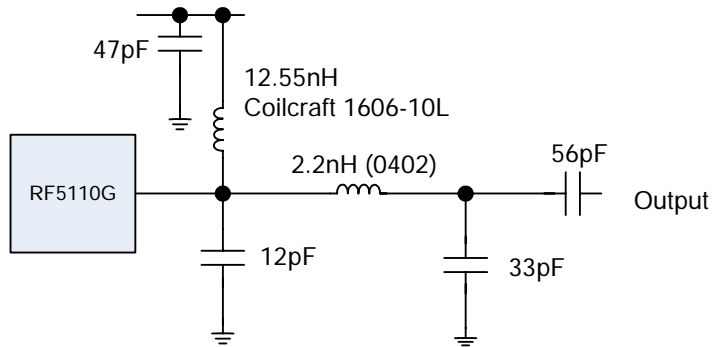

Figure 10 - Output matching of RF5110G for 400MHz operation

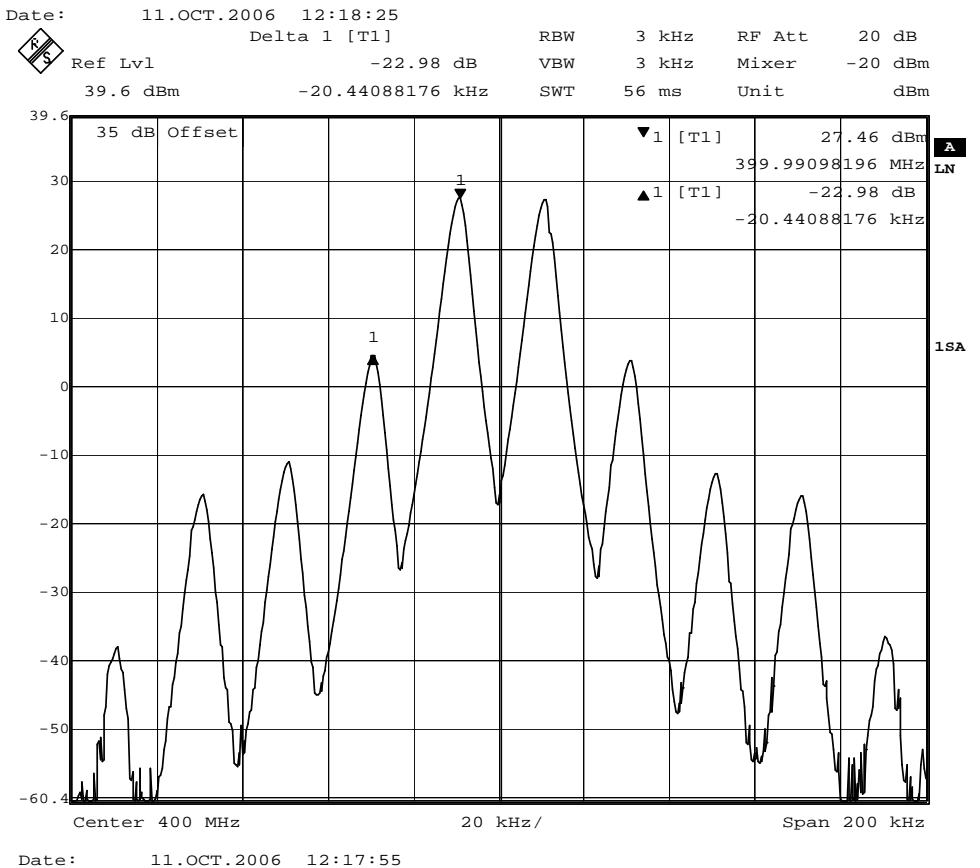
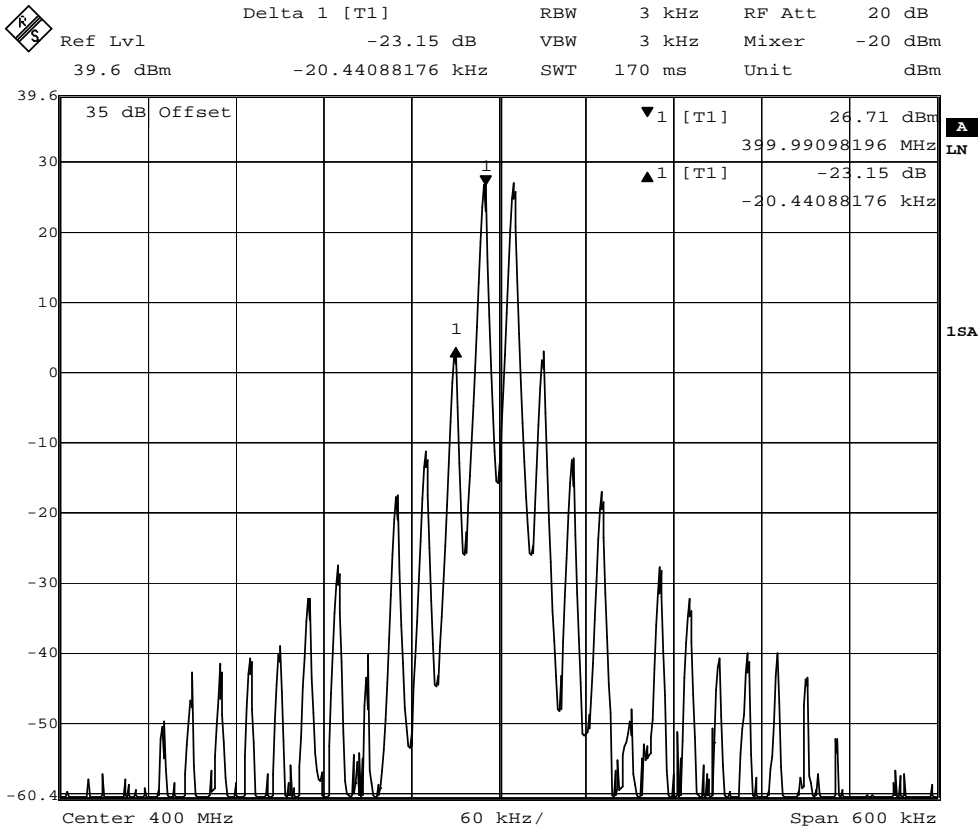

Figure 11 – RF5110G linearity at +33dBm PEP, V_{apc}=2.8V, V_{dd}=3.5V; note - Some cancellation of IMD products is present in the upper plot. This effect varies with V_{apc}.

4 CMX998 and RF5110G

4.1 Operation at 800MHz / 850MHz

The CMX998 was tested with the un-modified RF5110G evaluation card using the configuration shown in section 2. The RF5110G bias voltage (V_{bias}) was 2.8V and power supply was 3.5V.

4.1.1 Results at 850MHz

Results are shown in Figure 12 and Table 1 confirming the system provides excellent linearity and wideband noise performance compliant with TETRA requirements^[3] (see also Table 2).

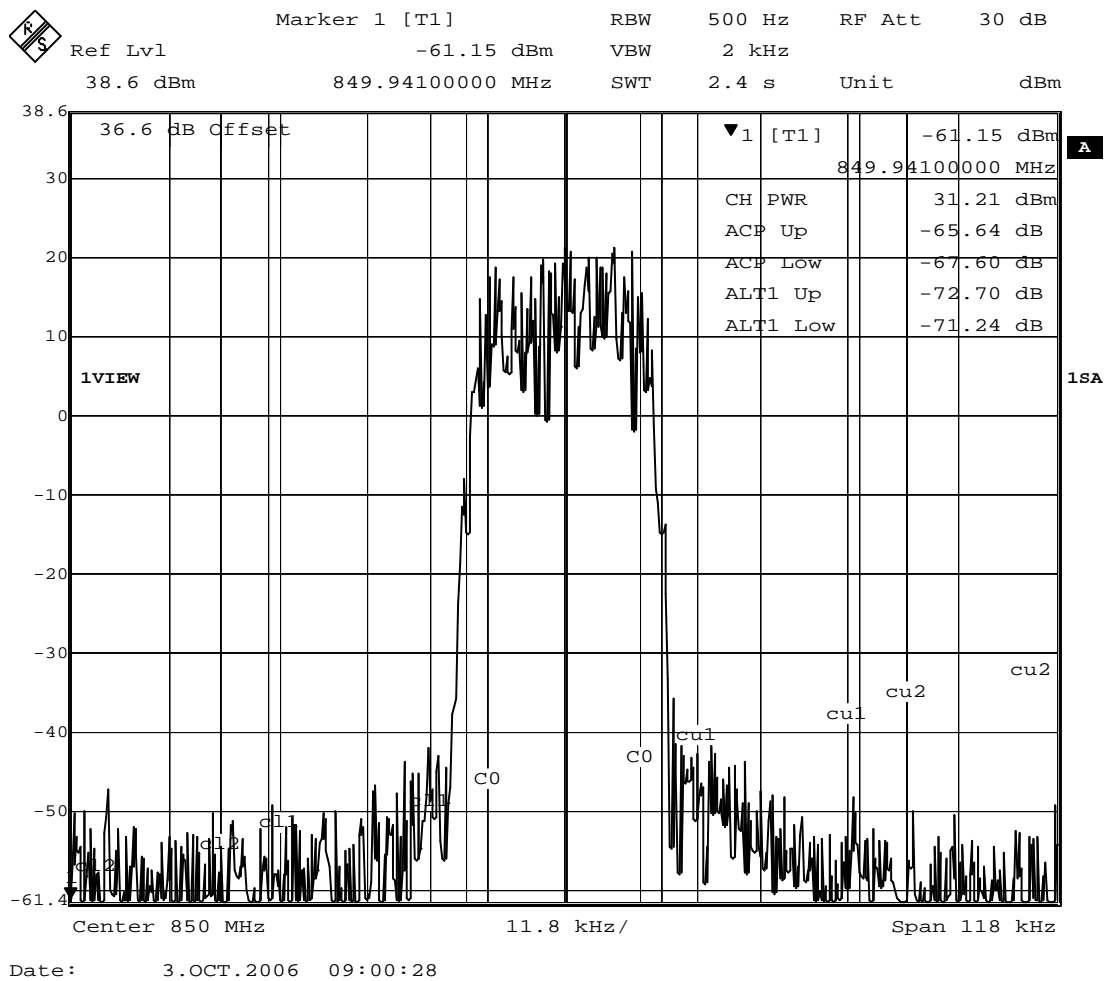

Figure 12 – CMX998 with RF5110G, adjacent and alternate channel performance at 850MHz

Table 1 shows measurement results of the noise at offset frequencies and compares them to TETRA specification points. All noise measurements were done with a mean output power of +30dBm (+33dBm PEP).

Offset (kHz)	Noise (dBc/Hz)	TETRA Requirements (1W/3W) dBc/Hz
-10000	-145.0 §	-142.6
-5000		n/a
-500	-132	-122.6/-127.6
-250	-126.5	-122.6/-122.6
-100	-120.5	-116.6/-116.6
+100	-120.5	-116.6/-116.6
+250	-127	-122.6/-122.6
+500	-130	-122.6/-127.6
+5000		n/a
+10000	-145.0 §	-142.6
§ - Wideband noise measurement may be limited by phase noise of 1.6GHz signal generator used as local oscillator.		

Table 1 – WBN Noise of Closed Loop including RF5110G at 850MHz

4.1.2 Results at 800MHz

The following tests were undertaken after the 400MHz tests (see section 4.2) with the RF5110G restored to 800MHz operation.

The RF5110G was found to deliver in excess of +31dBm mean power with TETRA modulation.

At +30dBm the Adjacent channel power of –69dB to –70dB was regularly observed. When the PA was operating continuously for extended periods, at +30dBm mean power or more, the ACP was never worse than –67dB to -68dB.

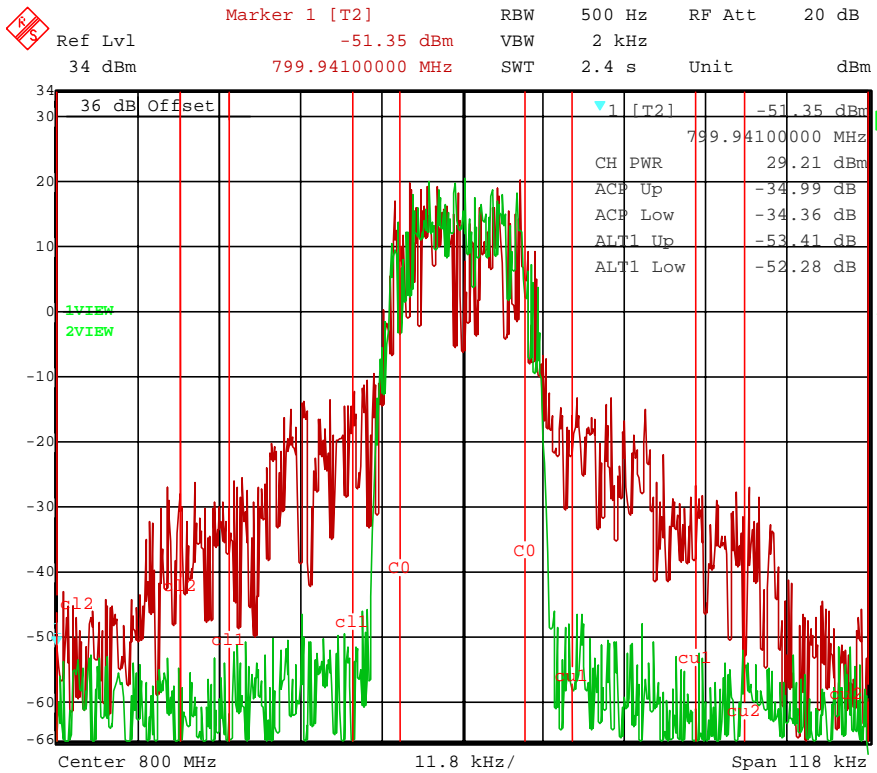

Date: 11.OCT.2006 15:04:57

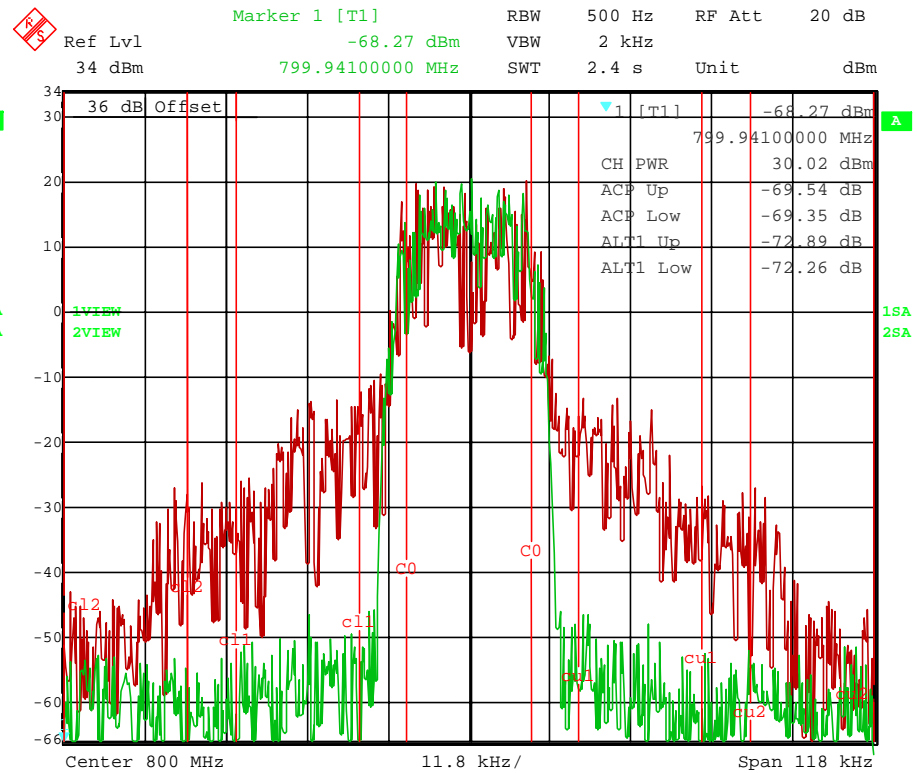

Date: 11.OCT.2006 15:05:38

Figure 13 - Open and closed loop performance of CMX998 & RF5110G at 800MHz. The measurements listed in the upper right hand corner of the screenshots show performance of the open loop system (left) and closed loop (right)



Ref Lvl
30 dBm

RBW 5 kHz RF Att 20 dB
VBW 2 kHz
SWT 200 ms Unit dBm

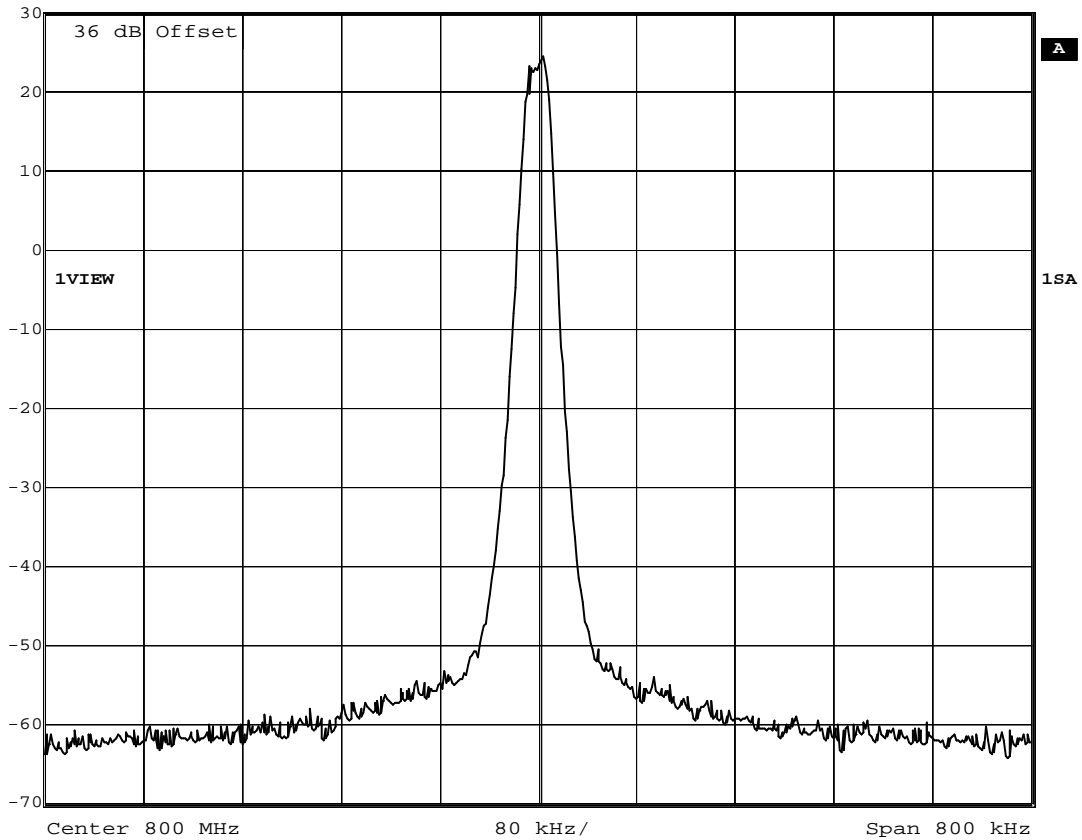

Date: 11.OCT.2006 15:30:20

Figure 14 – Broadband spectrum produced by CMX998 with pi/4 DQPSK modulation, +30dBm mean power output

4.1.3 Operation with SMIQ

Some spurs were noted on the output spectrum with the CMX981 at +/-500kHz. Although the spurs were at a low level, the operation of the CMX998 / RF5110G was checked using a TETRA baseband I/Q source from an SMIQ signal generator. The result was a clean output spectrum as can be seen in Figure 15.

A measurement issue was observed during these tests. It was found that the spectrum analyzer was limiting the measurement of the 2nd adjacent channel. This is because the analyzer automatically switches into 'wide' PLL mode for ACP measurements. While this is optimal for the 1st adjacent channel, the 2nd adjacent channel performance is limited by the phase noise of the spectrum analyzer. The effect can be demonstrated by forcing the FSEA into 'narrow' PLL mode, the result is seen in Figure 17 and can be compared with 'wide' mode in Figure 16.

The calculated linearization improvement is:

	Adjacent (+/-25kHz)	Alternate (+/-50kHz)
Open Loop	-34dB	-53dB
Closed Loop	-68dB	-75dB
Linearization Improvement	34dB	22dB

Table 2 – Typical Linearization improvement of CMX998 with RF5110G at 800MHz

The EVM (Error Vector Magnitude) of the transmitter is shown in Figure 18. At around 3%, it is well within most system requirements.
 (Note that no compensation correction or calibration is applied to achieve this figure).

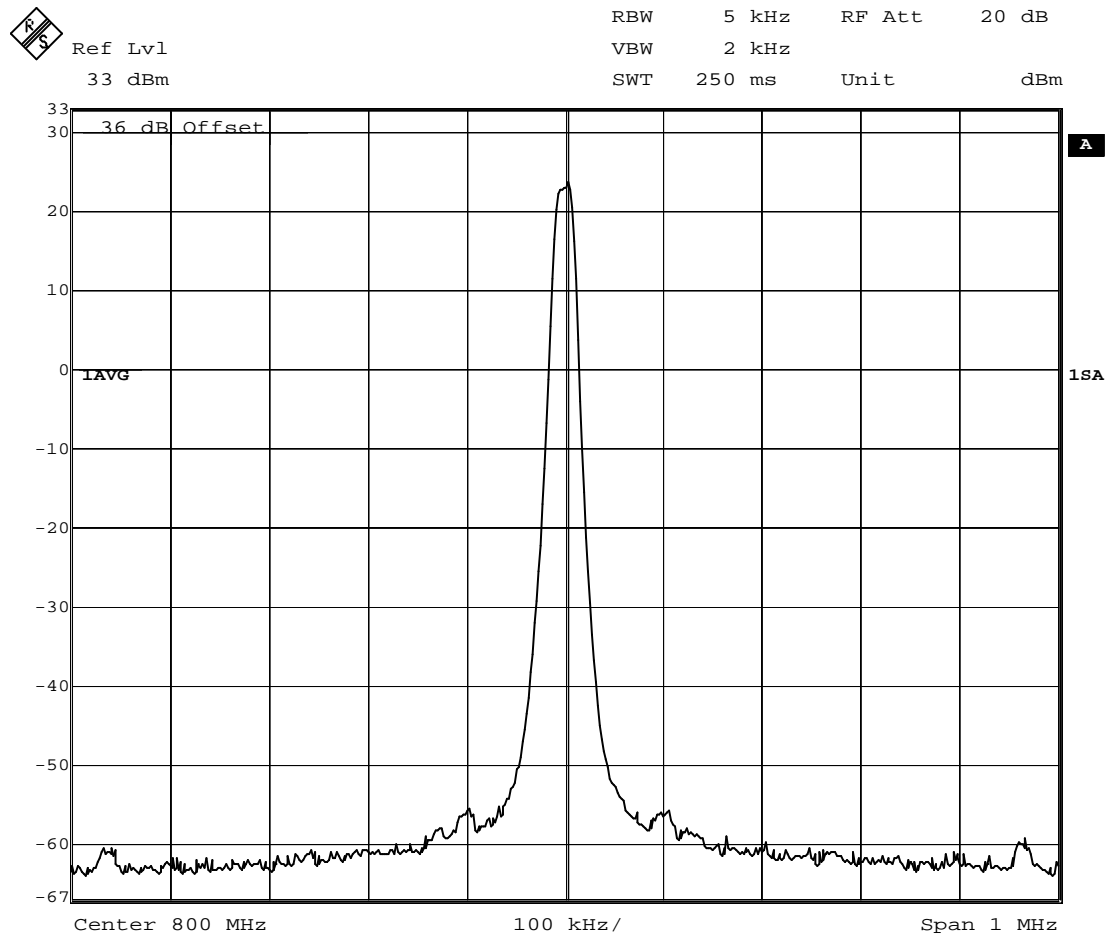

Date: 11.OCT.2006 16:25:24

Figure 15 - CMX998/RF5110G output spectrum, closed loop, +30dBm output power with I/Q from SMIQ signal generator

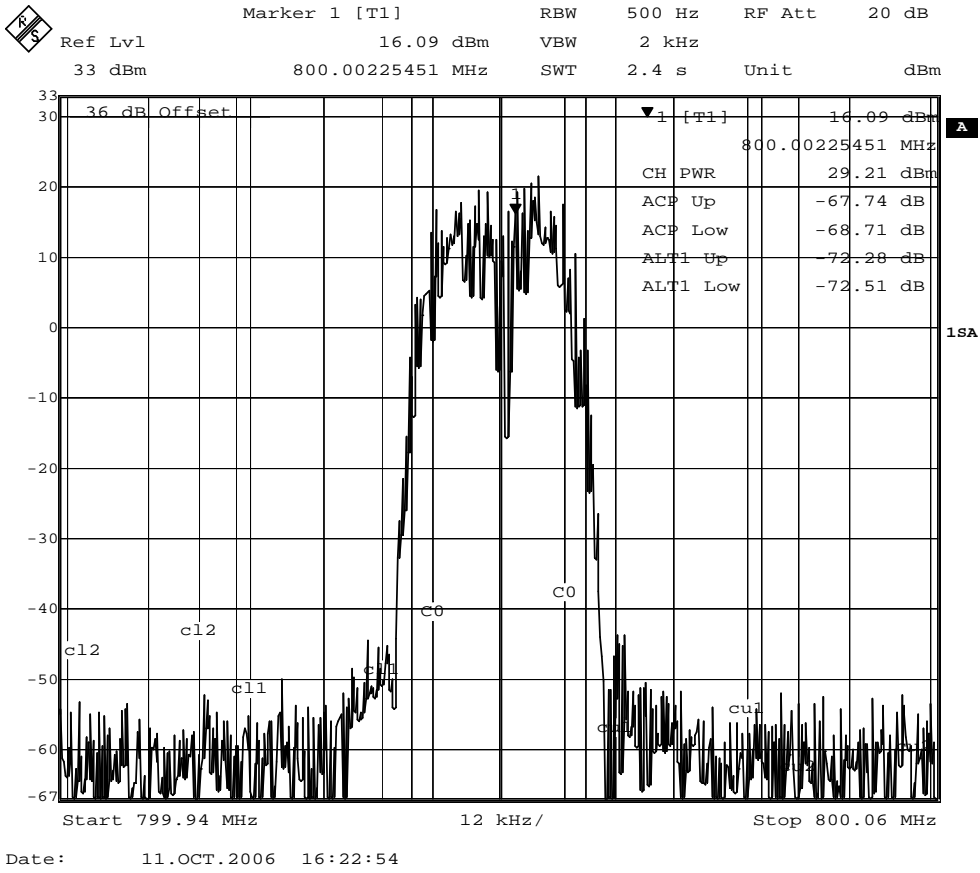

Figure 16 – Measurement with FSEA set to wide PLL

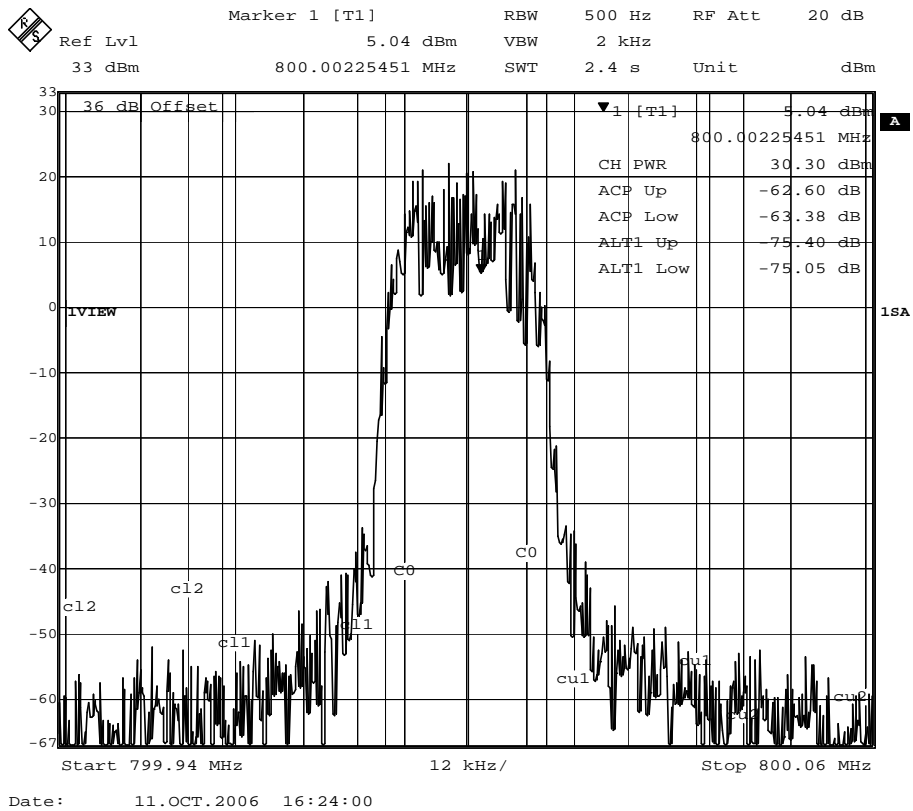
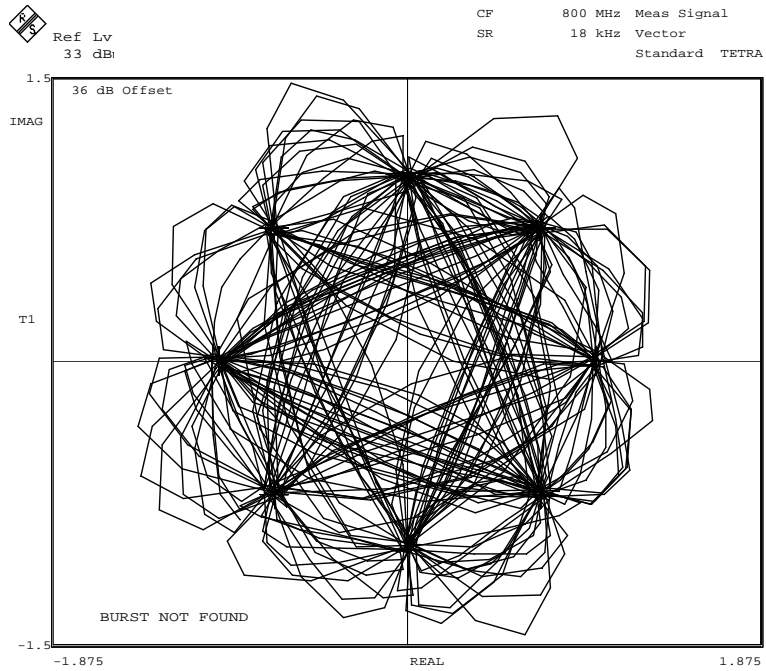

Figure 17 – Measurement with FSEA set to narrow PLL



Date: 11.OCT.2006 16:26:52



Ref Lv
33 dB

Marker 1 [T1]
Value

0 sym CF 800 MH
2 SR 18 k

Symbol/Erro:
Standard TET

36 dB Offset		Symbol Table			
0	10101001	10011101	11110101	01001100	00111111
40	10101000	10000001	11110011	00000100	00101010
80	00011000	11111100	01010010	00001001	11101100
120	00110100	01101000	10111001	01110011	10010111
160	00101001	01110010	11110111	00101110	00110010
200	11100100	10101110	01011011	11100101	11011000
240	01011100	11010001	11001010	11100100	10111110
280	01011011	10000101	11011001	00011100	11010110
320	01001010	11110101	10111110	00111101	10000100
360	10001101	00011011	00101110	01011010	11100101
400	11011110	01011100	11000101	11001010	10011100
440	10111111	01001011	10000011	10111001	00001001
480	10010110	0011			

Error Summary		BURST NOT FOUND	
Error Vector Mag	2.96 % rms	8.71 %	Pk at sym 5
Magnitude Error	2.10 % rms	5.64 %	Pk at sym 158
Phase Error	1.21 deg rms	4.40 deg	Pk at sym 44
Freq Error	-6.06 Hz	-6.40 Hz	Pk
Amplitude Droop	0.73 dB/sym	Rho Factor	0.9990
IQ Offset	1.18 %	IQ Imbalance	0.80 %

Date: 11.OCT.2006 16:30:29

Figure 18 - EVM with SMIQ signal source.

4.2 Operation at 400MHz

Using the modified RF5110G (see section 3.2), operation was tested at 390MHz and 400MHz. The RF5110G bias voltage was 2.8V and power supply was 3.5V. Results were extremely encouraging as can be seen from the excellent linearity in the following plots.

The adjacent channel power improvement is shown in Figure 19 and is summarized in Table 3. The improvement in the alternate channel is probably limited somewhat by other factors rather than pure linearization gain available (see section 4.1.3).

	Adjacent (+/-25kHz)	Alternate (+/-50kHz)
Open Loop	-34dB	-55dB
Closed Loop	-68dB	-72dB
Linearization Improvement	34dB	17dB

Table 3 – Linearization improvement of CMX998 with RF5110G at 400MHz

Table 4 shows measurement results of the noise at offset frequencies and compares them to TETRA specification points. All noise measurements were done with a mean output power of +29.5dBm (+32.5dBm PEP).

Offset (kHz)	Noise (dBc/Hz)	TETRA Requirements (1W/3W) dBc/Hz
-5000	-147.5	-142.6
-500	-130.5	-122.6/-127.6
-250	-127.5	-122.6/-125.6
-100	-122	-117.6/-120.6
+100	-122	-117.6/-120.6
+250	-127.5	-122.6/-125.6
+500	-132	-122.6/-127.6
+5000		-142.6

Table 4 – WBN Noise of Closed Loop including RF5110G @385MHz

Modulation accuracy requirements are well within TETRA specifications (Figure 20). Please note that these results are not compensated for I/Q imbalance in the CMX998 feedback path. The inherent EVM in the CMX981 modulation² is also a significant factor in the EVM measurement.

² TETRA pi/4 DQPSK modulation filtering is optimized for a combination of good adjacent channel power and EVM. Choices that were made to achieve good ACP increased EVM in the modulation.

◆ Marker 1 [T2] RBW 500 Hz RF Att 20 dB
 Ref Lvl 10.87 dBm VBW 2 kHz
 35 dBm 400.00201002 MHz SWT 2.4 s Unit dBm

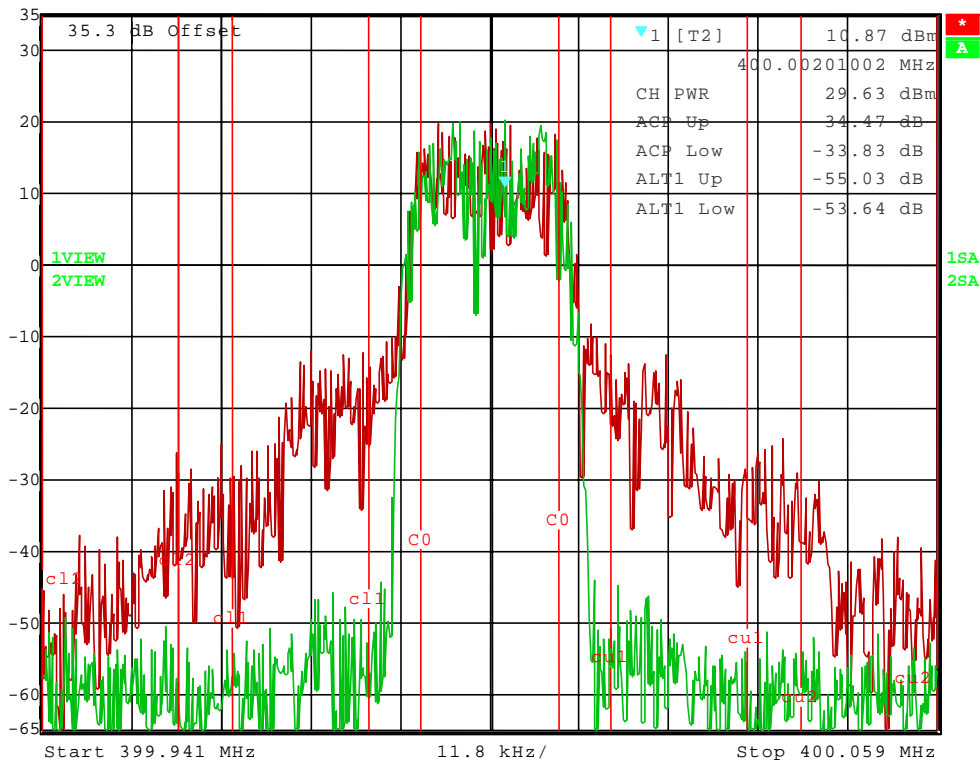

Date: 10.OCT.2006 16:48:08

◆ Marker 1 [T1] RBW 500 Hz RF Att 20 dB
 Ref Lvl 20.02 dBm VBW 2 kHz
 35 dBm 400.00201002 MHz SWT 2.4 s Unit dBm

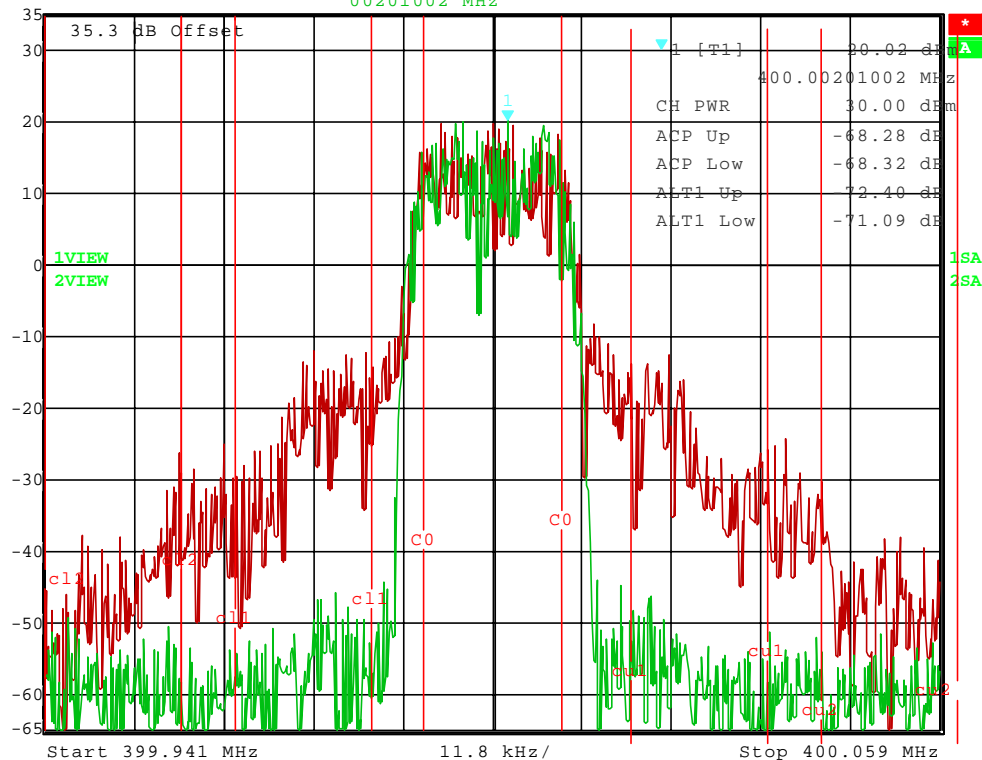

Date: 10.OCT.2006 16:47:30

Figure 19 - Open and closed loop performance of CMX998 & RF5110G at 400MHz. The measurements listed in the upper right hand corner of the screenshots show performance of the open loop system (left) and closed loop (right).



Ref Lv
35 dB

CF 400 MHz
SR 18 kHz Symbol/Errors
Standard TETRA

35.3 dB Offset	Symbol Table				
0	10100100	01011111	00110001	10101110	11011010
40	00010001	11011000	00111111	11111101	01110001
80	11111000	10011111	00100001	00011100	11100000
120	11010010	01111101	00010100	10101101	01011100
160	01101000	01001000	01001110	00011100	00001100
200	11101101	10000000	01100101	01010101	11000011
240	01001001	01010100	10101110	11001110	01110001
280	11111001	00101101	00111001	00111101	10001011
320	00000111	01001000	10100010	00100011	11110001
360	10011100	01111000	11111010	01110100	11011111
400	10101001	10000110	11010011	11011010	11011100
440	10100101	01000101	01110001	01110011	10010111
480	00001011	1010			

Error Summary		BURST NOT FOUND	
Error Vector Mag	4.94 % rms	9.95 %	Pk at sym 213
Magnitude Error	3.50 % rms	-7.83 %	Pk at sym 176
Phase Error	2.01 deg rms	5.57 deg	Pk at sym 4
Freq Error	81.17 mHz	4.22 Hz	Pk
Amplitude Droop	0.95 dB/sym	Rho Factor	0.9976
IQ Offset	1.46 %	IQ Imbalance	3.77 %

Date: 10.OCT.2006 15:17:06

Figure 20 - Modulation performance of CMX981 / CMX998 / RF5110G at 400MHz

5 Conclusions



The CMX981/CMX998/RF5110G combination has been found to perform very well at both 400MHz and 800-850 MHz. TETRA requirements for a 1W transmitter are easily achieved. Modulation linearity is very good and wideband noise is typical of CMX998 performance.

The RF5110G appears to be a good choice of a RoHS compliant power amplifier module to use with the CMX998. It serves applications around the 1W power level over a broad range of frequencies.

6 References

- [1] CMX998 Cartesian Feed-back Loop Transmitter datasheet, Ver. 5, November 2006
- [2] CMX981 Advanced Digital Radio Baseband Processor datasheet, Ver. 1, September 2002
- [3] ETSI EN 300 392-2 Terrestrial Trunked Radio (TETRA) voice and data. Part 2: Air Interface V2.4.2 (2004-02)
- [4] RF5110G datasheet see www.rfmd.com

CML does not assume any responsibility for the use of any circuitry described. No IPR or circuit patent licenses are implied. CML reserves the right at any time without notice to change the said circuitry and this product specification. CML has a policy of testing every product shipped using calibrated test equipment to ensure compliance with this product specification. Specific testing of all circuit parameters is not necessarily performed.

 CML Microcircuits (UK) Ltd <small>COMMUNICATION SEMICONDUCTORS</small>	 CML Microcircuits (USA) Inc. <small>COMMUNICATION SEMICONDUCTORS</small>	 CML Microcircuits (Singapore) Pte Ltd <small>COMMUNICATION SEMICONDUCTORS</small> Singapore China	
Tel: +44 (0)1621 875500 Fax: +44 (0)1621 875600 Sales: sales@cmlmicro.com Tech Support: techsupport@cmlmicro.com	Tel: +1 336 744 5050 800 638 5577 Fax: +1 336 744 5054 Sales: us.sales@cmlmicro.com Tech Support: us.techsupport@cmlmicro.com	Tel: +65 67450426 Fax: +65 67452917 Sales: sg.sales@cmlmicro.com Tech Support: sg.techsupport@cmlmicro.com	Tel: +86 21 6317 4107 +86 21 6317 8916 Fax: +86 21 6317 0243 Sales: cn.sales@cmlmicro.com.cn Tech Support: sg.techsupport@cmlmicro.com
- www.cmlmicro.com -			